

CHEMICAL PROCESSING

LEADERSHIP | EXPERTISE | INNOVATION

Powder eHandbook



Effective Powder Processing

SIZE REDUCTION SOLUTIONS

CHALLENGE



SOLUTION

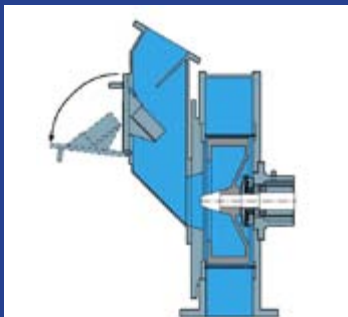

Universal Mill

With interchangeable grinding elements, the versatile Universal Mill allows maximum grinding flexibility for fine and ultra-fine particle size reduction.

[Find Out More >](#)

CHALLENGE



SOLUTION

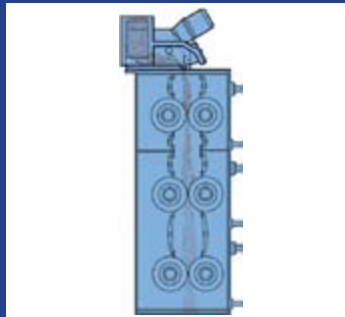

Roll Crusher

Narrow particle size distribution is achieved by controlling a combination of variables including roll speed, roll gap, differential speed, feed rate and roll surface design.

[Find Out More >](#)

CHALLENGE



SOLUTION

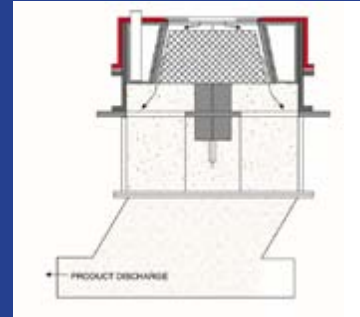

Gap Mill

The Gap Mill features an adjustable grinding gap between the conical shaped rotor and a corrugated baffle for fine grinding down to the 25 μ m size.

[Find Out More >](#)



601 Corporate Woods Pkwy
Vernon Hills, IL 60061
901-363-0921
www.bauermeisterusa.com



TABLE OF CONTENTS

Heat of Compression Dryers: Low Energy Consumption, Optimal Air Quality	6
Orthman Releases High-Capacity Bucket Elevators	9
Start Breaking Down the Borders!	11
How to Predict Powder Flow Behavior	15
Vibratory Screen Cleaning Methods Improve Screening Efficiencies and Save Money	20
Prevent Fine Powder Flushing	25
Vac-U-Max Introduces Bulk Bag Discharger	30
A Q&A on Horizontal Motion Conveying	32
Tubular Drag Conveying Technology	36
Bauermeister Introduces New Universal Mills	40
This is Not “Dust” So I Don’t Have a Problem!	42
Cyclonaire Boosts Production, Reduces Spillage at P&G	46
Explosion Pressure Relief: Vent or Door?	51



AD INDEX

Bauermeister www.bauermeisterusa.com	2
Vac-u-max www.vac-u-max.com	5
Atlas Copco www.atlascopco.us/usus	10
Summit Training Source www.safetyontheweb.com	14
Brookfield Engineering www.brookfieldengineering.com	19
Sweco www.sweco.com	24
Orthman Conveying Systems www.conveyusa.com	27
Federal Equipment Company www.fedequip.com	31
Triple S Dynamics, Inc. www.sssdynamics.com	35
Hapman www.hapman.com	41
Fauske www.fauske.com	45
Cyclonaire www.cyclonaire.com	50
Fike www.fike.com	54

The Smartest Distance Between Two Points....

Pneumatic Conveying Systems by VAC-U-MAX

VAC-U-MAX is a premier manufacturer of custom pneumatic conveying systems and support equipment for conveying, vacuum conveying, batching, and weighing materials. With a VAC-U-MAX pneumatic conveying system on site, your company's product can move gently and quickly from point to point, with nothing in the way to impede the efficiency of its movement.

- Dilute Phase Vacuum Conveying Systems
- Dense Phase Vacuum Conveying Systems
- Dilute Phase Positive Pressure Conveying Systems
- Dense Phase Positive Pressure Systems
- Multi-ingredient Handling
- Batch Weighing Systems
- Bulk Bag Unloading
- Bulk Bag Loading
- Bag Dump Stations
- Vacuum Conveyors
- Aero-Mechanical Conveyors
- Flexible Screw Conveyors



Pneumatic Conveying Systems * Bulk Bag Unloaders * Bag Dump Stations * Flexible Screw Conveyors * Aero-mechanical Conveyors



VAC-U-MAX

69 William Street
Belleville, NJ 07109
T:973-759-4600 * F: 973-759-6449
info@vac-u-max.com

www.vac-u-max.com or call 800-VAC-U-MAX (822-8629)



Heat of Compression Dryers: Low Energy Consumption, Optimal Air Quality

SUPERB QUALITY compressed air is an essential ingredient for an efficient and productive plant, but air that is inadequately treated can cause extensive damage to equipment, processes and products. One crucial air treatment process is drying. When air is compressed, the moisture naturally present in ambient air is concentrated. A dryer eliminates this moisture before it can get into the air network, where it is extremely difficult to remove.

There are three general types of dryers in the market: refrigerant, desiccant, and heat of compression. Most people who work with compressed air are familiar with desiccant and refrigerant dryer technologies. Though they are well established, many superior advantages are offered by today's most advanced dryer technology, heat of compression dryers.

REFRIGERANT DRYERS

A refrigerant dryer uses a refrigerant circuit and heat exchanger(s) to pre-cool air, refrigerate it to remove moisture vapor via condensation, and then reheat the air to prevent pipe sweating downstream. Refrigerant dryers can lead to a pressure dew point (PDP) as low as +37.4°F/+3°C for many applications where there is a need for dry air. They can be used at different pressures and consume no processed compressed air. The main types of refrigerant dryers on the market include:

- Direct expansion dryers.
- Fixed speed non-cycling dryers that run continuously regardless of varying load conditions.

- Fixed speed cycling dryers that shut down at lower loads to save energy and restart when required.
- Variable speed dryers that cycle automatically according to demand.

DESICCANT DRYERS

A desiccant dryer consists of two towers filled with desiccant such as activated alumina, silica gel or molecular sieve. While one tower is drying compressed air, the other is being regenerated. Desiccant dryers can achieve dew points as low as -40°F/-40°C and -100°F/-70°C. Three types of desiccant dryer are widely used throughout industry:

- Heatless purge dryers use a small portion of the dried compressed air for regeneration.
- Heated purge dryers use a small and heated portion of the dried compressed air for regeneration.
- Heated blower purge dryers use heated ambient air for regeneration.

HEAT OF COMPRESSION (HOC) DRYERS

Compressing any gas, including air, produces heat. Heat of compression drying recycles heat energy from the compressor to regenerate the desiccant. An HOC dryer requires only a very small amount of electric power for regeneration, and operation is continuous and fully automatic. When used in place of a refrigerant or desiccant dryer, it also eliminates the related power consumption (direct or purge). Atlas Copco's unique zero purge technology consumes no compressed air due to purge, so there is no need to oversize



the compressor installation to compensate for purge losses.

WHICH DRYER IS RIGHT FOR ME?

To find out, consider this simple formula: ACE, which stands for Applications, Customers and Environments.

Applications – What dew point do you need to achieve? Do you have very low temperatures in the winter and very high temperatures in the summer? Refrigerant dryers are not compatible with freezing temperatures, so if the equipment is located outside or has compressed air piping that is exposed to outside air (which is very common), being able to cope with a negative dew point will be required and desiccant dryers will be required.

Customer – What quality of air is demanded for the customer’s application and their end products? For general applications where only protection against corrosion is needed, a refrigerant dryer is enough. However, an HOC dryer – even if it requires a higher initial investment – can pay for itself through lower operating costs and provide similar or better dew points. Applications with more stringent requirements, such as when compressed air is in contact with food, will require dew point of at least -40°F/-40°C to remove sufficient moisture content. Guaranteed dew point HOC or desiccant dryers, sized to take into account the maximum operating conditions, will then be the right choice. Even more demanding

applications, such as electronics manufacturing, may require -100°F/-70°C special versions with molecular sieve or HOC or desiccant dryers.

Environment – Does the compressed air system run 24/7? What size compressors are running? Can higher investment costs easily be recovered through smaller energy bills?

Blower purge desiccant, zero purge, and HOC dryers employ more sophisticated designs and, not surprisingly, are more expensive to purchase. However, these technologies benefit customers in the long term because energy savings can pay back the extra initial investment. Additionally, reducing or eliminating purge loss brings higher outlet flow, so in most cases a smaller combination of compressor and dryer can be used. That can save even more.

Atlas Copco offers an industry leading, energy efficient range of compressed air dryers with options for technology, size and configuration to suit any application.

MD/ND HEAT OF COMPRESSION INTEGRATED DRYERS

- Class 2 and Class 3 dew point performance (see figure 1)
- (Class 2 = -40F and below, Class 3 = -4F and below)
- Instrument quality dry air
- Guaranteed dew point (ND and MD with low load kit)

ISO 8573-1:2010	Dirt			Mass concentration mg/m ³	Water		Oil Total oil (aerosol liquid and vapor) mg/m ³
	Maximum number of particles per m ³ 0.1 - 0.5 micron	0.5 - 1 micron	1 - 5 micron		Vapor pressure dewpoint	Liquid g/m ³	
0	As specified by the equipment user or supplier and more stringent than Class 1						
1	≤ 20000	≤ 400	≤ 10	-	≤ -70°C/-94°F	-	0.01
2	≤ 400000	≤ 6000	≤ 100	-	≤ -40°C/-40°F	-	0.1
3	-	≤ 90000	≤ 1000	-	≤ -20°C/-4°F	-	1
4	-	-	≤ 10000	-	≤ +3°C/+37.4°F	-	5
5	-	-	≤ 100000	-	≤ +7°C/+44.6°F	-	-
6	-	-	-	≤ 5	≤ +10°C/+50°F	-	-
7	-	-	-	5 - 10	-	≤ 0.5	-
8	-	-	-	-	-	0.5 - 5	-
9	-	-	-	-	-	5 - 10	-
X	-	-	-	> 10	-	> 10	> 10

Figure 1. Explaining the different ISO classifications.



- Low operating costs
- 104-5,300 scfm

Atlas Copco owns multiple patents for the drum dryer design which makes MD/ND HOC dryers unique. This design re-uses most of the energy consumed during compression and reduces or eliminates purge losses while offering the lowest life cycle cost.

An Atlas Copco MD HOC dryer can be coupled with a low load kit to achieve ISO Class 3 dew point. An ND HOC dryer equipped with a heater can guarantee ISO Class 2 dew point performance.

MD/ND dryers are fully integrated into the Full Feature variant of Atlas Copco's ZR/ZT oil-free compressor range. In cases where HOC drying needs to function as a free-standing solution, MD/ND dryers can be installed downstream of an Atlas Copco oil-free or centrifugal (ZH Turbo) compressor. They also can be used with a competitor's oil-free unit.

XDE/XD HEAT OF COMPRESSION REACTIVATED ADSORPTION DRYERS

- Extremely dry low dew point air
- -40°F/-40°C PDP as standard, -100°F/-70°C PDP is available
- Low operating costs
- 700-14,400 scfm

Atlas Copco's XDE/XD adsorption dryers remove moisture from compressed air to ensure system reliability, maximize productivity, and minimize service and repair costs. They can address even the most stringent air quality requirements. One XD dryer can dry the air of several compressors. In fact, Atlas Copco's XD dryer range offers a unique value proposition when coupled with our ZR and ZH compressors or with a competitor's compressor.

Atlas Copco's Adaptive Regeneration Technology actively controls the regeneration parameters, responding to changing working conditions while optimizing the total energy needs. Combined with advanced Elektronikon® controls, the dynamic heating sequence optimizes total energy needs.

Atlas Copco was first to offer an HOC adsorption dryer for extremely low dew points. The

XDE330-1100 (700-2,300 scfm) range includes dew point dependent switching, the exclusive Elektronikon® graphic control panel with remote visualization, and filter pressure drop monitoring.

Unlike competitive solutions, the patented XD Zero Purge can use both installed coolers during the complete cycle time, thereby lowering the load on the desiccant and the energy required for regeneration.

BD+ LOW ENERGY DRYERS (BLOWER HEATED DESICCANT DRYER)

- Energy savings when HOC dryers are not an option
- Zero Purge variant available
- -40°F/-40°C PDP guaranteed, -100°F/-70°C PDP available
- 200-6,350 scfm

In situations where HOC drying is not an option (for instance, when not enough heat is available or byproduct heat is already recycled for additional energy savings elsewhere), energy savings can still be achieved by minimizing purge consumption. Atlas Copco offers the BD+ 100-3000 range (212-6,350 scfm), a blower heated desiccant dryer that is available in either a purge or a Zero Purge variant (BD+ 350 and up). All BD+ models are equipped with the Elektronikon color graphic controller that monitors all the operating parameters and offers free remote visualization. The BD+ is also available in a -100°F/-70°C PDP version. Larger BD+ models (350-3000) also have a unique split flow cooling that avoids temperature spikes at tower changeover, and are available in -100°F/-70°C combined with Zero Purge. Up to BD+1100, Zero Purge is based on an air cooled closed loop (above water cooled). Dry compressed air is not used during the desiccant cooling cycle, eliminating the average 2 percent loss used by purge models.

In some cases, the difference of purge consumption between a blower purge and heatless desiccant dryer is such that for the same outlet flow, a smaller size of compressor and dryer can be used, contributing to a faster payback of this energy-saving technology.



DRYERS SHOULD BE “ENVIRONMENTALLY FRIENDLY”

Atlas Copco recently introduced a campaign – “STOP Using R22 Refrigerant Dryers” – to raise public awareness of the harmful environmental effects of using R22 refrigerants in industrial and commercial applications, including refrigerant dryers. R22, commonly known by its brand name, Freon, is a halocarbon compound which has the potential to cause depletion of the ozone layer in the atmosphere.

Because Atlas Copco is committed to sustainable productivity, we offer a variety of dryers with refrigerants such as R410A, R404A and R134a that do not deplete the ozone. Our commitment is in line with international conventions that are banning the use of R22 in a phased manner.

DRYERS SHOULD PROTECT THE CUSTOMER’S INVESTMENT

Under the United Nations’ Vienna Convention for the Protection of the Ozone Layer and the resulting Montreal Protocol, R22 refrigerant is to be phased out by 2020 in order to reduce the abundance of R22 in the atmosphere, thereby protecting the fragile ozone layer. Since 2010, R22 can only be used for service of existing machines in the United States and not for new machines. Beginning in 2020, only recycled R22 will be allowed for service.

DRYERS SHOULD PROTECT THE ENVIRONMENT

The fact that the ozone layer was being depleted was confirmed by international treaty in the mid-1980s. The main cause of this is the release of chlorofluorocarbons (CFCs), a category of chemicals which includes R22 refrigerants.

The importance of the ozone layer is to protect the earth from the sun’s harmful ultraviolet (UV) rays. Overexposure to UV radiation can cause a range of health effects on humans and animals, including skin cancers. In addition, UV rays have been shown to cause eye damage and suppression of the immune system.

CONCLUSION

Drying compressed air is a relatively simple science, until you factor in variants such as energy usage and quality control. After that, the decision can become a more complex puzzle that requires thoughtful analysis. Often, all three of the technologies would do the “simple job” that you need a dryer to perform, but does the purchase “cost” outweigh the “value” that this dryer should add to your energy bill and also help improve your production quality? Atlas Copco’s compressed air experts are trained to find the right solution for you and will provide a payback analysis to which we are committed and indeed proud to stand behind.

Orthman Releases High-Capacity Bucket Elevators

Buckets feature capacities up to 2,000 tons per hour and elevator heights up to 250 feet.

ORTHMAN CONVEYING Systems has released its line of bucket elevators with capacities up to 2,000 tons per hour. These “super capacity” elevators are intended for use in the chemical, cement, clinker, coal, lime, frac sand, charcoal, and cullet industries and are available with elevator heights up to 250 feet.

Centrifugal or continuous types are available, with belt or chain drives as per facility needs. The units can be used with gravity or screw takeups and are made with materials from carbon fiber to stainless steel. Outboard bearings are included as a standard, and unsupported elevators for above silo applications are designed and supplied.

For more information, visit conveyusa.com.



Clear the way for quality air



Hi, I'm **Michelle** and I have been working with our customers across the United States for the last 10 years. Products that optimize quality in your air supply are not just accessories we offer; they are a way of life for us at Atlas Copco. That's why we produce such a wide variety of dryers, aftercoolers, filters and oil-mist eliminators just to name a few.

We all perform best when working within our optimum environment, right? And, manufacturing environments are no different. Moisture in your air supply is something that should be avoided at all costs. Water is a by-product of compressing air. But there are ways to ensure this moisture doesn't get downstream and cause equipment malfunction. And more importantly, moisture can lead to contamination of your end products, leading to costly product failures and potentially harming your hard-earned reputation.

Our mission is to continue to bring sustainable productivity through safer, cleaner, more energy-efficient, and cost-effective compressed air technology. Simply log onto www.atlascopco.us/michelleusa or call **866-688-9611** to learn more about us, our products, and how we have earned and will continue to earn our reputation.



Sustainable Productivity

Atlas Copco



Start Breaking Down the Borders!

Here's Your Quick Info Guide on the New GHS

"EXPOSURE TO hazardous chemicals is one of the most serious threats facing American workers today," said U.S. Secretary of Labor Hilda Solis. "Revising OSHA's Hazard Communication standard will improve the quality and consistency of hazard information, making it safer for workers to do their jobs and easier for employers to stay competitive."

If you haven't started already, the sooner hazardous communication can be universalized, the better for all workers and employers who deal with hazardous materials. More than ever, we live in a global economy that is built around the use of chemicals. In the United States alone, 650,000 chemicals in the workplace are classified as hazardous, and from their production, to their use and transport, they pose a risk to workers and the environment. The challenge is to keep these workers well-informed and safe. The new regulations for the Globally Harmonized System (GHS) of Classification and Labeling of Chemicals have been in place since May, and though the timeline for implementation gives some leeway over the next few years, get ahead and do it now.

OSHA's recently released Hazard Communication Standard (HCS) updates the 25-year-old regulation by incorporating the GHS, created to strengthen international efforts that concern the environmentally sound management of classifying and communicating hazardous chemicals. The basic goal of GHS is to provide adequate, practical, reliable, and comprehensible information on the hazards of chemicals to ensure preventive and protective measures for health and safety are taken around the world, benefiting governments, companies, workers, and members of the public.

According to OSHA, it was recognized that an internationally harmonized approach to classification and labeling would provide the foundation for all countries to develop comprehensive national programs to ensure the safe use of chemicals. Thus, the new GHS will break down the borders of communication for the effective classification and labeling of a hazardous chemical, regardless of its origin.

MAJOR CHANGES

Hazard classification: Provides specific criteria for classification of health and physical hazards, as well as classification of mixtures.

Labels: Chemical manufacturers and importers will be required to provide a label that includes a harmonized signal word, pictogram, and hazard statement for each hazard class and category. Precautionary statements must also be provided.

Safety Data Sheets: Will now have a specified 16-section format.

Information and training: Employers are required to train workers by December 1, 2013 on the new label elements and safety data sheets format to facilitate recognition and understanding.

In the revised standard, one of the major changes is how hazards are classified. According to ASSE, EHS professionals are about to be flooded with changes to current MSDS and labels that must be revised, rewritten, and republished to comply with new GHS regulations and hazard communication standards, detailing how to classify health and physical hazards, as well as instructions for chemical mixtures. With the previous standard, there was much more leeway in how manufactures and distributors could classify and communicate hazards, creating



all the more reason why companies and employees should become familiar with the new globalized product/chemical hazard identifier symbols sooner rather than later.

The information required on the safety data sheet (SDS) will remain very similar to the current standard, which indicates what information has to be included on an SDS but does not specify a format for presentation or order of information. The revised HCS requires that the information on the SDS is presented using a consistent, specified sequence by designating the headings of information to be included on the SDS, the order in which they are to be provided, and what information is to be included under each heading. In addition to being consistent and easy to read, the changes made to labeling and safety data sheets will enable employees that are exposed to workplace chemicals to more quickly obtain and more easily understand information about the hazards associated with those chemicals, which have also been redesigned to include a red border. Moreover, the SDS format is the same as the ANSI standard format that is already familiar to many employees by being widely used in the U.S.

THE BENEFITS OF GHS

By providing globally understandable information on appropriate handling and safe use of hazardous chemicals, the revised standard will improve several aspects of the workforce, the workplace and the environment. Here are the main benefits to the revision:

Enhance the protection of human health and the environment: Consistent and widespread use of GHS will enhance protection of human health and the environment by providing an internationally comprehensible system for hazard communication. GHS will help ensure more consistency in the classification and labeling of all chemicals, thereby improving and simplifying hazard communication. This improved communication system will alert the user to the presence of a hazard and the need to minimize exposure and risk, resulting in safer transportation, handling and use of chemicals.

Promote sound management of chemicals worldwide: GHS will provide a harmonized basis for the first step in the sound management of chemicals, identifying hazards and communicating them. This will be particularly useful for countries without well-developed regulatory systems.

Improve businesses that deal with hazardous chemicals: This update will also help reduce trade barriers and result in productivity improvements for businesses that regularly handle, store, and use hazardous chemicals, all while providing cost savings for the businesses that periodically update safety data sheets and labels for chemicals covered under the hazard communication standard.

Facilitate trade: GHS will reduce costly and time-consuming activities needed to comply with multiple classification and labeling systems, promoting more consistency in regulation and reducing non-tariff barriers to trade.

Reduce the risks of exposure: The revisions are expected to improve the use of appropriate exposure controls and work practices that can reduce the safety and health risks associated with exposure to hazardous chemicals. OSHA expects that the modifications to the Hazard Communication Standard will reduce the numbers of accidents, fatalities, injuries and illnesses associated with exposures to hazardous chemicals, resulting in the prevention of 43 fatalities and 585 injuries and illnesses (318 non-lost-workday injuries and illnesses, 203 lost-workday injuries and illnesses, and 64 chronic illnesses) annually. The monetized value of this reduction in occupational risks is an estimated \$250 million a year on an annualized basis.

Increase savings: OSHA estimates that the revised HCS will result in savings of \$475.2 million from productivity improvements for health and safety managers and logistics personnel, \$32.2 million during periodic updating of SDSs and labels, and \$285.3 million from simplified hazard communication training.

Anticipated productivity benefits: OSHA foresees three types of productivity benefits: (1) for chemical manufacturers, because they will



EFFECTIVE DATE	REQUIREMENT	WHO IT AFFECTS
Dec. 1, 2013	Train all employees on the new label elements and Safety Data Sheet format	Employers
June 1, 2015	Comply with all modified provisions of this rule, except distributors that are allowed to ship products labeled by manufacturers under the old system until Dec. 1, 2015	Chemical manufacturers, importers, distributors, and employers
Dec. 1, 2015	Comply with all modified provisions of the rule	Distributors
June 1, 2016	Update alternative workplace labeling and hazardous communication program as necessary, and provide additional employee training for newly identified physical or health hazards	Employers

need to produce fewer SDSs in future years; (2) for employers, in providing training to new employees as required by the existing OSHA HCS through the improved consistency of the labels and SDSs; and (3) for firms engaging in, or considering engaging in, international trade.

WHO WILL BE AFFECTED?

OSHA estimates that over 5 million workplaces in the United States would be affected by the revised HCS. These are all those workplaces where employees — a total of approximately 43 million of them — could be exposed to hazardous chemicals. Included among these 5 million workplaces are an estimated 90,000 establishments that create hazardous chemicals; these chemical producers employ almost 3 million workers.

TIMELINE

Companies that work with chemicals are expected to have trained their employees on how to read the new material safety data sheets (MSDS) and labels by June 1, 2013, and to have all employee training completed by June 1, 2016. Listed above is a closer look at important dates that you need to know.

DON'T WAIT

The time is now to start your training on the new GHS standard. Educating employees on the updated chemical and product classifications and related pictograms, signal words, hazard statements and precautionary measures will represent the greatest training challenge. Training will be a key component of the overall GHS approach and should incorporate information as it is introduced into the workplace. Employees and emergency responders will need to be trained on all new program elements, from hazard statements to pictograms. Also, if products are imported from countries that implement GHS prior to the United States and Canada, employee training may need to begin earlier than expected. By starting to address GHS as soon as possible, companies can make a difficult, lengthy task more manageable.

KATHERINE MCCARTHY is the communications coordinator for Summit Training Source, Inc. Putting her expert writing skills to work, Katherine researches, writes, and manages Summit's blog, as well as numerous white papers, articles and marketing collateral. Katherine holds a Bachelor of Science degree in Business Administration from Grand Valley State University and can be reached at Katherinem@safetyontheweb.com or @SafetyTraining1 on Twitter.

REFERENCES:

1. "Globally Harmonized System (GHS) for Classification and Labelling of Chemicals." Pesticides: International Activities. Environmental Protection Agency, 9 May 2012. Web. 11 July 2012. <www.epa.gov/oppfead1/international/globalharmon.htm>.
2. "Hazard Communication." Occupational Safety & Health Administration. United States Department of Labor, n.d. Web. 11 July 2012. <www.osha.gov/dsg/hazcom/>.
3. Morrison, Kyle W. "GHS Is Here." Safety & Health May 2012: 40-43. Web.
4. Walter, Laura. "ASSE: Don't Delay on Addressing GHS Compliance." EHS Today. Penton Media, Inc., 21 Mar. 2012. Web. 11 July 2012. <<http://ehstoday.com/standards/osha/ASSE-Addressing-GHS-Compliance-0321/>>.

IT'S THE DAWN OF A **NEW ERA** IN SAFETY TRAINING...

**SUMMIT'S *NEW* SAFETY RESOURCE
LETS SAFETY COME TO YOU!**

Experience the rise of a NEW, indestructible Summit safety resource to uphold your fight against the lurking, evil incidents and accidents!

INTRODUCING...

Summit Safety Alliance

Bringing world-class, onsite training consultants powered with Summit's extraordinary training programs to your work-site to ensure injury prevention measures are taken and compliance needs are met.

JOIN FORCES TO EXPERIENCE THESE BENEFITS:

- Specific safety and compliance training
- Industrial Hygiene sampling
- Assistance with regulatory investigation responses
- Expert testimony
- Assistance with startup companies to develop a safety program
- Filling a gap in between full time safety professionals

Keep your workers safe and productive by teaming up with the SSA... and witness the NEW safety resource for yourself... contact us today!



www.safetyontheweb.com | 800.842.0466
eLEARNING • STREAMING VIDEO • DVD

1230-0087

How to Predict Powder Flow Behavior

By Robert G. McGregor, Brookfield Engineering Laboratories

FORMULATORS ARE constantly modifying powders for enhancements that will either improve the processing operation and/or benefit the end user's needs. Modifications designed to enhance product quality and help the end user sometimes have an adverse impact on processing. Manufacturing is well aware of difficulties in getting reliable discharge from gravity feed hoppers because this is the type of problem that can temporarily shut down the line. When the cause is a change in formulation, manufacturing always wants to know beforehand whether there will be an impact on processability. Because process scale-up information for new formulations seems to be more art than science, the team on the production floor vigilantly monitors the discharge flow behavior in case there is a significant deviation from predicted powder outflow.

The need for reliable instrumentation that can predict flow behavior changes in gravity discharge has grown to a point where formulators will try any one of a number of devices to get a handle on this challenging problem. Popular instruments, such as the flow cup or angle of repose tester, are simplistic, but do not correlate well or consistently with the changes observed in flow behavior on the production floor. Tap tests provide useful information on compressibility of the powder, but this may not correlate back to the question of flowability. The shear cell and uniaxial tester are two devices that address the key parameter which dictates powder flow behavior, namely the consolidating stress that is experienced by powder stored in a bin before it starts to flow.

WHAT IS CONSOLIDATION?

When powder is placed in a bin, the settling process begins immediately. As more powder is added, the extra weight applies increasing pressure on the material in the bottom of the bin. Some of the air trapped between the powder particles is squeezed out and the particles move closer to one another.

An observer might detect that the fill level is able to reduce without any powder being discharged out the bottom. This is consolidation.

The question is how to measure the consequence of this consolidation phenomenon. Powder gains strength as the particles move closer to each other. This strength, in turn, will resist gravity's effort to cause flow. So how do we measure this powder strength?

UNIAXIAL TESTERS

The University of Greenwich in England has spawned an enterprise known internationally as The Wolfson Centre for Bulk Solids Handling Technology. This organization is both a training ground for aspiring engineers intent on pursuing a career in powder handling and a consultant to industry for solving powder processing problems. One tool that they have created to illustrate the consolidation phenomenon for powder stored in a bin is the Sand Castle Kit. It consists of a box of dry sand, a cylindrical sleeve for making the sand castle, various weights and a graduated cylinder for adding a measured amount of water (see Figure 1).

The fundamental idea is that the dry sand, when placed in the sleeve, has no strength in and of itself to remain standing when the sleeve is removed. As



Figure 1: Sand Castle Kit for conducting uniaxial test.



Figure 2: Dry sand forms a pile with "Angle of Repose" relative to horizontal.

everyone knows, the dry sand collapses and forms an almost horizontal pile (see Figure 2). The slight angle that can be observed relates to a measurement which industry uses, called "Angle of Repose" or "Angle of Inclination," on materials that are stored in stockpiles. The intent is to correlate this angle with the flowability of the material when discharging from a bin.

By adding a small amount of moisture to the dry sand, mixing thoroughly, and then placing it once again in the sleeve, the wetted sand gains strength. It may actually hold together when the sleeve is removed. The test procedure at this point, before removing the sleeve, places a 1kg weight on the sand (see Figure 3). As soon as this happens, the height of the sand in the sleeve reduces by a small amount because air trapped in the sand is pushed out as the sand particles move closer to one another. The sleeve is removed and a free standing sand castle remains.

What is the strength of the sand in the free standing castle? In essence, the frictional resistance between the sand particles must be stronger than the influence of gravity, which would bring the sand castle crashing down if it could. The procedure for determining the strength is to place small individual weights on the structure until it collapses. Now it is possible to record the amount of weight which the castle will support, in this case 50g (see Figure 4). This weight value is called the "unconfined failure strength" of the material.

The test is now repeated with the exception that the consolidating weight used to compress the sand in the sleeve is doubled to 2kg. The reduction in height of the compressed sand seems to be slightly greater than before. This time, 170g in weight is required to collapse the free standing sand castle. The pattern



Figure 3: A 1kg Weight is placed on wetted sand causing consolidation.



Figure 4: A 50g weight causes the sand castle to collapse.



seems obvious. The more weight that is used to consolidate the sand when building the castle, the more strength it will have.

Data from this type of test is plotted in Figure 5. The x-axis shows the amount of weight used to compress the sand in the sleeve. The term used by industry is “consolidating stress.” The y-axis shows the amount of weight which the sand castle supports before collapsing. Industry refers to this as “unconfined failure strength.”

Flow behavior of powder stored in a bin can be modeled by this type of experiment. The fill level in the bin equates proportionally with the consolidating stress felt by the particles at the bottom. The resistance to movement correlates with the unconfined failure strength that can be measured in this type of a test.

The Johanson Hang Up Indicizer is an instrument that has been used for many years by industry to make this type of measurement. Similar to the sand castle test, it creates free standing cylinders of powder, and then fails them in a uniaxial direction. This allows the user to generate a data table that compares unconfined failure strength vs. consolidating stress.

SHEAR CELL METHODOLOGY

Another long-established practice for evaluating powder flow behavior is the Shear Cell (see Figure 6). High acquisition cost and the need for skilled operators to run the instrument have prevented most manufacturers from using this methodology. Recent breakthroughs in the redesign of this device, simplifications in the test procedure, and the

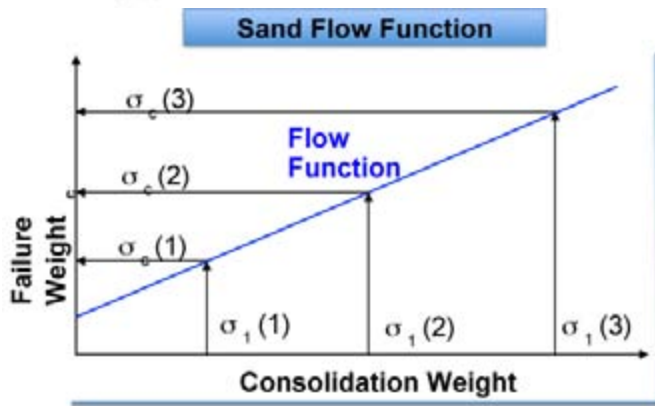

Figure 5: This graph shows sand strength vs. consolidating weight.

automation of test execution now make it possible for most manufacturers to consider this technique.

The powder sample is weighed, then placed in the trough which fits onto the instrument turntable (see Figure 7). The vane lid compresses the powder in the trough to a defined consolidating stress. Pockets in the vane lid allow powder particles to fill this space. After the consolidating stress has been applied, the trough rotates through a relatively small angular displacement. Friction between powder particles located in the shear plane (intersection of trough and lid) causes the vane lid to rotate with the trough. The vane lid is connected to a torsional spring monitored by a torque sensor. When the torque resistance exceeds the frictional force between the powder particles in the shear plane, the vane lid stops movement. The peak torque and steady state torque values are recorded.

This shearing test is repeated at various levels of



Figure 6: Shear cell components include a trough and vane lid.



consolidating stress to ultimately create a picture of powder flow behavior known as the Flow Function. The x-axis is the consolidating stress which indicates the compressive force applied to the powder sample in the trough by the vane lid. The y-axis is a measure of the powder's strength which indicates its ability to resist movement. Industrial experts have agreed upon defined regimes of flow behavior as shown on the graph in Figure 8:

- Free Flowing
- Easy Flowing
- Cohesive
- Very Cohesive
- Non-Flowing

Most powders will exhibit an ability to flow more readily at higher consolidating stress. This situation correlates with a bin that is full of powder. The self-weight of the powder in the bin is substantial, relatively speaking, and applies significant downward force on the powder in the hopper section. At lower consolidating stress, the powder may exhibit increasing resistance to flow, which is shown by the Flow Function transition in Figure 8 from Easy Flowing to Cohesive. This situation correlates with a bin that has reduced fill level. The physics is simply a matter of less powder weight being available to force the powder out the hopper opening.

CONCLUSION

Industry has moved toward the use of shear cell methodology to characterize flow behavior in gravity discharge. The ability to quantify the change in flow behavior is now possible with the use of the Shear Cell. In addition, the ability to predict arching and ratholing are accomplished with easy calculations that result from the Flow Function data.

ROBERT G. MCGREGOR is the General Manager-Global Marketing and High-End Lab Instrument Sales at Brookfield Engineering Laboratories and can be contacted at r_mcgregor@brookfieldengineering.com.



Figure 7: The Brookfield Powder Flow Tester uses the shear cell methodology.

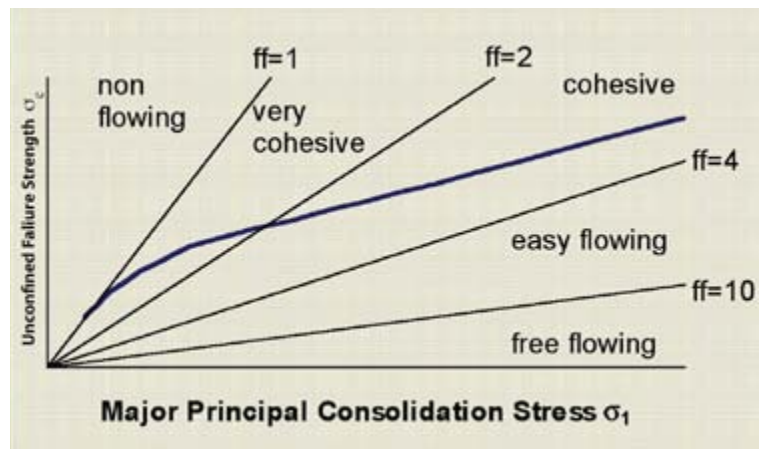

Figure 8: Flow Function characterizes powder strength vs. consolidating stress.



When you really need to know the flow of your
POWDER...

PFT™

Powder Flow Tester

...affordable testing for powder characterization

ACCURATE TEST RESULTS
in minutes

IDEAL FOR MANUFACTURERS
who process powders daily
and have flow problems with
bins, hoppers, silos and feeders

QUICK & EASY ANALYSIS
of flow behavior using proven
scientific method ASTM D6128

CHOICE OF TESTS

- Flow Function
- Wall Friction
- Bulk density

CHOICE OF RESULTS

- Flow Index
- Arching Dimension
- Rathole Diameter
- Hopper Half Angle

R&D TOOL to predict flow behavior
for new formulations before scale-up

QC CHECK for incoming materials and final
product shipments



Vibratory Screen Cleaning Methods Improve Screening Efficiencies and Save Money

By Greg Brock, SWECO

SCREEN BLINDING occurs when the screen mesh openings are blocked or closed by the material which is being screened. Near-size particles become trapped or build up on the wires, effectively blocking the screen openings preventing further material from passing through the screen (see Figures 1A and 1B). This is a common screening problem which is easily fixed with screen cleaning devices. This article will review the most common methods of screen deblinding.

SCREEN CLEANING DEVICES

SLIDERS

The most common self cleaning device is the “slider” (see Figure 2). Slider rings are loose rings which slide directly beneath the screen surface on a slider support surface, normally a perforated metal plate. The rings are bounced vertically into the screen mesh by the vertical motion of the separator as they travel radially around the screen. The sliders are activated by the motion of the separator with out additional driving force.

Sliders are especially good on fine mesh because of the low impact energy and the shearing wiping action which cleans the screen openings. Sliders can be used in both wet and dry screening applications.

Sliders work by four different methods depending on the material properties.

- Vertical separator motion impacts the slider ring on the bottom of the mesh, dislodging trapped near-size particles out of the screen mesh openings, effectively cleaning the screen and opening the mesh for the next particle to be screened.
- The slider shears or breaks protruding hard or friable materials into smaller pieces which flow through the screen, clearing the openings.
- If the material is soft and pliable, the sliders can help the material through the screen openings.
- If the material is fibrous, the sliders horizontal scrubbing motion across the bottom of the screen will dislodge trapped fibers from the screen openings, improving throughput capacity.

Sliders are not efficient for materials which

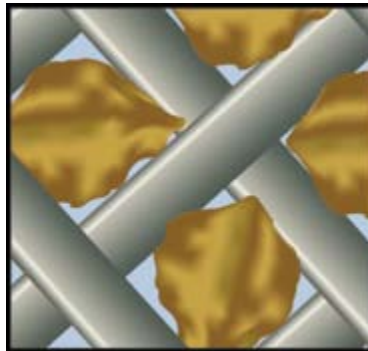

Figure 1A: Trapped near size particles block screen openings from further material classification.

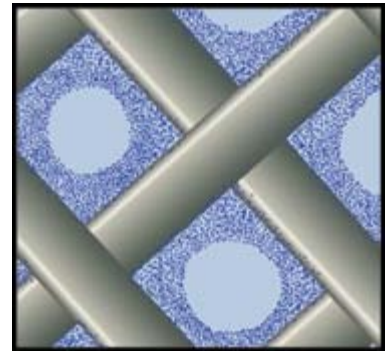

Figure 1B: Fine material build-up or caking blocks the screen openings from further material classification.

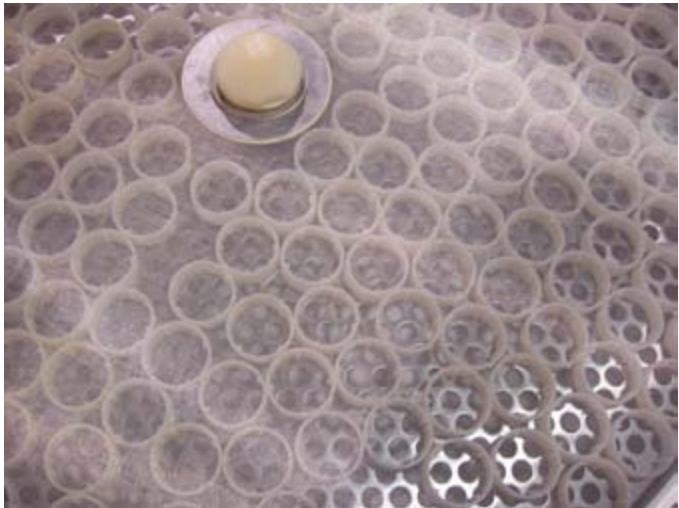

Figure 2: Sliders travel across the top of a perforated plate. The motion of the vibratory separator throws the sliders into the screen as they rotate around the center of the machine.

tend to ball up or agglomerate inside the sliders. Sliders also generate minor amounts of heat, which can fuse temperature sensitive materials. Sliders may not perform well on extremely hard irregular shaped materials, which can partially protrude through the screen opening and stop the motion of the slider.

Slider clusters (see Figure 3) work on essentially the same principles as slider rings. The difference is



Figure 3: Here, single slider rings are shown in the lower left, slider clusters center top, and rubber balls on the lower right.



Figure 4: Self cleaning kit balls bounce between a support screen and the classifying screen. The vertical motion of the separator launches the balls and generates the screen cleaning action.

the size is 4 to 8 times larger than a slider ring. Slider clusters are normally used for large diameter machines for easier maintenance. The impact force is higher due to the larger weight and size, but there are fewer impacts due to the reduced number of clusters.

There are mixed reports on whether individual sliders or larger slider clusters are a more effective self cleaning method. The effectiveness is completely governed by the material being screened.

BALL TRAYS

Rubber balls are the second most utilized screen cleaning method, but can only be used for dry screening. The rubber balls are generally 1-3/8-in. diameter and are supported by a second coarser mesh two inches below the classifying screen mesh. Higher vertical separator motion is required to activate the ball cleaning action because the balls must be thrown up against the bottom of the screen (see Figure 4).

The larger vertical motion and higher weight balls impart more energy to each impact as compared to sliders or clusters. As a result of the higher impact energy, balls are generally used for coarse meshes which can withstand higher impact energy from the balls. Balls are not recommended for fine screen meshes because mesh damage can occur.

Balls are very good at cleaning near-size irregular or jagged shape particles wedged in mesh openings. These same type materials can trap sliders. Balls are also very good for shear sensitive materials where smearing or balling agglomeration can occur. Balls are not recommended to clean fibrous materials because there is no shearing action to dislodge fibers from the mesh.

The disadvantage of ball trays is that the balls spread radially to the periphery of the screen. This generates excellent cleaning action at the screen edge, but leaves the center of the screen uncleaned.

SANDWICH SCREENS

Sandwich screens are made by bonding a classifying mesh to the top of the screen tension ring and a coarser support screen mesh to the bottom of the ring. This creates a sandwich with screen cleaning devices floating between meshes. This sandwich construction improves cleaning action, decreases maintenance costs and decreases noise levels.

Cleaning action is improved because sliders are more active bouncing off the bottom mesh as compared to a standard perforated metal plate. The bottom mesh acts more like a trampoline launching cleaners into the mesh more efficiently. The construction also locates the cleaners closer to the classifying mesh allowing a more gentle vibratory motion to provide better cleaning action.

Screen life and motor life are increased because the improved cleaning efficiency of sandwich screens requires less vertical vibration amplitude than standard sliders and balls. Maintenance costs are reduced with increased screen and motor life and screen changes are quicker with the cartridge design of sandwich screens.

Sandwich screens allow the combination of smaller balls inside each slider, which can yield better results than sliders or balls individually. The sliders provide complete coverage of the screen surface, and a ball inside each slider holds the balls into position which provides for the ball cleaning action across the



entire screen. The smaller balls yield the ideal impact energy and can be used on fine meshes.

Sandwich screens can be used for dry or wet screening and can be fabricated with metal or synthetic meshes. Sandwich screen bottom screen meshes are much better for wet screening because the liquids cannot build up unlike perforated plates.

Finally, sandwich screens are quieter, decreasing noise levels over other screen-cleaning solutions.

TOP SIDE SCREEN CLEANING METHODS

In addition to the bottom side self-cleaning methods, there are top side cleaning devices which reside on top of the classifying screen mesh. These can be divided into three classifications: brushes, wipers and dams.

TOP SIDE ROTARY BRUSHES

The top side rotary brushes are exceptional for clearing fibrous materials which tend to mat on top of the screen and block the mesh openings. The rotary brushes move around the screen diameter propelled by the vibratory motion of the separator — no additional driving motors are required. The brushes ball up the fibrous mat above the screen to expose screen openings. The fiber balls are then discharged from the top of the screen and out the spout.

The disadvantage to the top side brushes is the bristles which can be lost into the product streams.

TOP SIDE NECKLACE RING DAMS

Top side necklace rings create a radial edge dam to keep materials on the active screen longer. The longer

some materials are on the screen, the higher the capacity throughput. This can increase the yield of smaller machines to match the capacity of larger machines.

TOP SIDE WIPER RING

Top side wiper rings (see Figure 5) provide the same radial edge dam as a necklace, but also add a wiper which improves capacity with an additional shearing action. This shearing action can wipe fatty materials through the screen mesh, or break up friable clumps to improve capacity or reduce loss. The disadvantage to top side wipers is that they slow or impede material flow through the machine. Materials which tend to ball up should never use a top side wiper.

VIBRO RIM

Vibro rim screens are made by inserting metal ball bearings inside the hollow screen tension ring. The balls create a secondary vibrational energy by impacting the screen tension ring when moved by the vibratory motion of the separator. The ball impact energy is transmitted to the screen mesh through the ring. This excitation helps clean the radial edge of the screen. This is good for synthetic meshes where unacceptable wear and damage can occur from sliders or balls. The disadvantage is that only the outer two inches of the screen is excited and cleaned.

WATER SPRAYS

Water sprays clear screen mesh openings, help eject solids, and keep slurries from drying out and building up inside separators. Another spray advantage is there is no contamination from slider, ball or brush materials. The disadvantages of liquid sprays are cost and potential dilution of products.

Stationary spray nozzles are good for cleaning the mesh openings and washing fine particles from over-sized solids.

Rotary spray nozzles are very good for deblinding and ejecting fibrous or lint-type materials.

ULTRASONIC

Ultrasonic screen cleaning uses vibrational energy generated by an ultrasonic frequency transducer attached to the metal screen mesh to generate the screen cleaning action (see Figures 6A and 6B). Ultrasonic assisted screening is good for high accuracy



Figure 5: A top side wiper ring slides around on top of the screen to help clean the screen mesh openings.



screening where the particle size approaches that of the mesh opening. Ultrasonic energy breaks down electrostatic charges and surface tension which agglomerate particles and prevent efficient screening.

The ultrasonic vibrational amplitude is 0.000005 inch occurring at a frequency of 35,000 times per second. The lower amplitude and increased frequency means that the particle lands on the screen openings approximately 1,000 times more often than a standard separator vibration, increasing the statistical chances that the particle will go through the mesh opening.

Ultrasonic screen cleaning is the most expensive separation process. Ultrasonic equipment costs are 10 to 20 times the cost of sliders and the consumable screen costs are four times the cost if a tension ring re-screening program is utilized. Therefore, it is only used on high-value materials and difficult screening operations which cannot be accomplished efficiently by any other method.

ENERGIZER

The energizer (see Figure 7) is a pneumatic screen vibration generator which operates at frequencies and amplitudes between ultrasonic motion and standard round separator. The pneumatic screen energizer can be used on both synthetic and metal screen meshes.

The multiple transducers generate a more uniform vibration across the entire screen surface, even on large diameter screens. The pneumatic generators do not use electrical energy and simple mechanical maintenance is required.

The energizer adds the effectiveness of high frequency screen excitation at a lower cost impact. Energizer system cost is 1/3 that of ultrasonic equipment and the disposable screen cost is 1/4 that of an Ultrasonic screen.

SUMMARY

- Sliders and slider clusters are the most common screen deblinding method for the majority of wet and dry vibratory separator processes.
- Ball trays are used for coarse mesh dry screen cleaning.
- Sandwich screens generate more efficient screen cleaning action than sliders on perf plates, or ball trays.
- Screen cleaning devices on the top side of the



Figure 6A: The Ultrasonic screen cleaning system is installed in a round vibratory separator. The externally mounted electrical control box powers the transducer affixed to the screen tension ring. The screen is bonded to the exciter ring which vibrates the mesh.

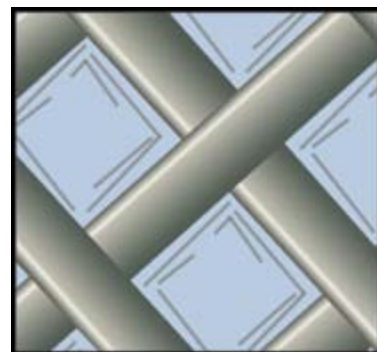

Figure 6B: This graph depicts an ultrasonically vibrating screen mesh.



Figure 7: The screen energizer is attached below the screen surface.

screen are less common and used for more specialized cleaning applications.

- Liquid spray cleaning methods are used for unique wet screen blinding issues.
- Ultrasonic screen cleaning is a high-frequency device which is very effective, but limited by the higher process cost.
- Pneumatic screen energizer systems yield the benefits of high frequency excitation at a lower cost.

GREG BROCK is a technical support representative for SWECO, 8029 US Highway 25, Florence, KY 41042; 800-80 SWECO, fax 859-727-5123 (greg.brock@sweco.com).



MX™ Round Separator

Patented In 1942. Perfected Every Year Since.

SWECO has been the global leader in separation technology for more than 70 years. From round, rectangular, gyratory, and centrifuge separators to aftermarket parts and screens, SWECO can engineer an innovative solution for your application.



**Round & Rectangular
Fusion™ Screens**



GyraMax™ Gyratory Sifters



We put technology in motion.™
www.sweco.com

©SWECO, a business unit of M-I L.L.C.

Prevent Fine Powder Flushing

Trapped air can cause fine powders to shoot through cracks and crevices. Here's how to eliminate this bin-afflicting problem.

By Lee Dudley, Diamondback Technology

WHEN A fine powder traps air between particles, it may exit a bin like it is in a pneumatic conveyor system, shooting through any crack or crevice, including poorly fitting or worn rotary valve vanes, screws, feeders, bolt holes, vibratory feeder pans or belt feeders, until the powder is depressurized. Yet once the powder settles and air is squeezed from voids between powder particles, it can plug feeders, arch over hopper outlets or cling to hopper walls and form a stable rathole, which creates equally unstable process conditions downstream.

Talc, lime, powder cleansers, fly ash, pulverized coal, resin, plastic powders, iron ore and cement are most susceptible to flooding and flushing.

THE CULPRITS

The interaction of powder and air cause flooding and flushing problems — they always require a source of pressurized air. Some of these sources include collapsing ratholes, back-pressure from baghouses, free-falling powder, air pads, improperly set air permeation units, rotary valves that feed pressurized pneumatic conveying systems (especially those that are not vented), and gas/solids units with gas counterflow. The three most common sources, however, are collapsing ratholes, free-falling powder and uncontrolled air injection.

Collapsing ratholes. The most frequent source of powder flushing is a flow pattern within a hopper that results in a rathole (Figure 1).

Usually this happens in conical hoppers when hopper walls are not steep enough to cause flow along the walls. As a result, flow is directed to a narrow central flow region while non-flowing material accumulates at the sides and eventually becomes an integral part of the hopper structure. If the rathole collapses or a high rate of powder is then introduced into the hopper, the incoming powder can entrain pressurized air, which will fluidize the powder and result in flushing through screw, belt and vibratory feeders, and

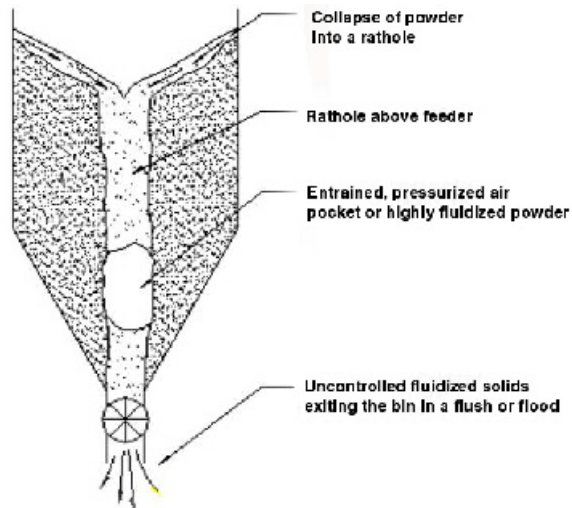

Figure 1. A rathole-type flow pattern is a common source of flushing.

even in rotary valves with an entrained air pressure of several psi.

Depending upon the hopper's outlet diameter and the strength of the material, a rathole may become destabilized and can peel off and collapse into the hopper, essentially flushing a large quantity of powder through the outlet and into any feeder below

Free-falling powder. Flushing also results when powder free falls into a hopper in a stream and traps air from the surrounding environment between particles (see Figure 2). The faster the powder flows, the larger the void or space between particles, and the greater the entrained air. As the powder accelerates, so does the air. When the powder strikes the top level of material in the bin, some air is dispersed into the atmosphere, creating dust. The rest of the air is trapped within the powder. If the hopper is small, relative to the flow rate out, and if the material within the hopper has a short retention time that doesn't allow the trapped air to escape, fluidized powder can flow at an uncontrolled rate through the outlet.

Uncontrolled air injection. A third cause of flushing is uncontrolled air injection or a chemical reaction



within the powder that produces gas (see Figure 3). Both can fluidize powder. The only circumstance in which uncontrolled air injection should be considered is in a pneumatic conveying system that transports powder subject to wide fluctuations in feed rate, or into a closed container such as a blow tank that may require a high charge rate to reduce the cycle time.

TACKLING THE PROBLEM

Properly addressing fine powder flooding and flushing starts with testing the material's flow properties to understand how the particular powder interacts with air and what its potential is for flooding and flushing. Often, this indicates that only minimal adjustments are required.

However, the typical approach for controlling or eliminating excess air that leads to flushing is to place a rotary valve at the hopper outlet. Unfortunately, the valve's rotating vanes actually pump air into the hopper outlet; so, instead of reducing excess air, the rotary valve supplies additional air. Eventually, the close tolerances between vanes wear down and flushing can occur.

Other ways plants deal with powder flushing are by building a settling chamber at each feeder, increasing a dust collector's capacity, over-filling packages to compensate for occasional underflow, and putting in automatically closing shut-off gates that activate whenever a paddle switch senses flushing.

Fortunately, there are better methods for preventing powder flushing. Potential solutions include: an air permeation system, a sloping let-down chute, a vertical pipe below the hopper, a deaeration cylinder, and hopper retrofits to correct flow patterns. Their costs can vary considerably.

Air permeation system. Powder will not flow at consistently high rates without some entrained air. When totally deaerated, flow rates may fall significantly below the rate required. When totally fluidized with indiscriminate air injection, as may be the case with air pads or pulse jets, the flow rate may increase, but so will the potential for sudden uncontrolled flushing.

An air permeation system with injection nozzles placed at critical positions in the hopper can control both the air pressure and rate of injection, and provide consistently high powder flow rates without the potential for severe flushing.

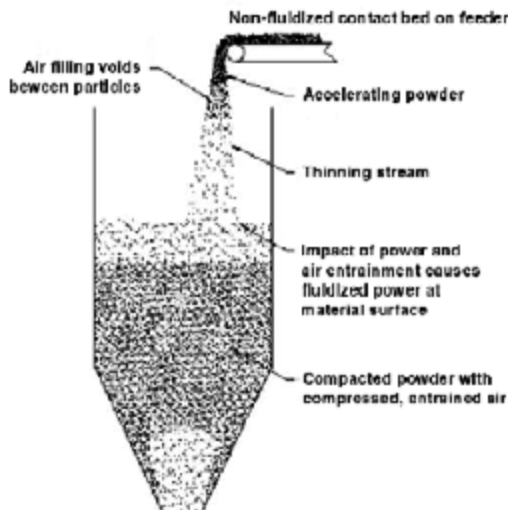

Figure 2. Free-falling powder can trap air between particles.

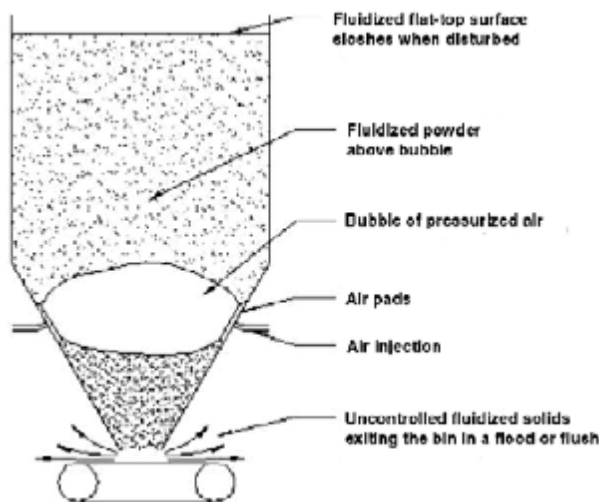

Figure 3. Uncontrolled air injection

Such a system can replace air lost when a powder compresses and thereby prevent an inrush of air from the outlet that could impede flow. The small amount of air needed to fill voids and increase the flow rate 10 or more times is not enough to create dust or fluidization.

An air permeation system needs to be designed to prevent over-pressure pulses as powder enters the hopper to keep powder from plugging the ports and to ensure powder flows both above and below the system (see Figure 4). Careful placement is crucial, as



Orthman

CONVEYING SYSTEMS



Screw conveyors



Bucket elevators



FAST • SMOOTH • EFFICIENT

- Totals systems integration, including specialized plants & facilities
- Top quality & durability, including many 'premium' options as standard

Orthman Conveying Systems

800-642-9551 conveyusa.com/powder

Planning an expansion?

Ask about

LASER-MAPPING YOUR EXISTING FACILITY

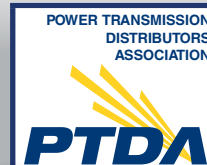



is properly adjusting air-permeation-system settings.

Vertical pipe below the hopper. A vertical, non-converging pipe placed below a hopper designed for flow at the hopper walls can substitute for an air permeation system because it tends to create a vacuum at the hopper outlet that pulls powder out (see Figure 5). This solution also increases the flow rate, sometimes by a factor of 10 or more, because the vacuum can be as great as the height of the vertical section multiplied by the powder's bulk density.

When using this solution to increase powder flow rates, it is essential to employ a feeder that controls the flow slightly below the limiting rate. Otherwise, the high rate of powder flow created from using the vertical section is sustained only as long as it is full of powder. Once the vertical section empties, the limiting flow rate is governed by the void above it and powder flow can slow dramatically.

Sloping let-down chute. Another reasonably inexpensive solution for powder flushing is an open let-down chute that protrudes into the powder surface at the top of the hopper and prevents air from circulating through and becoming trapped between powder particles, as is the case with a free-falling powder stream (see Figure 6). Although powder in the chute accelerates and thins as it descends, air entrainment is reduced or eliminated because powder is in contact with the chute surface. When placing a let-down chute, it is critical that the chute protrude into the surface of the powder so there is absolutely no powder free-fall. Even a free-fall drop of only a few inches can severely aerate a powder and increase its potential for flushing.

Deaeration cylinder. A deaeration section, composed of a perforated interior cylinder and a vented section in a cylindrical outer section, will remove excess air before it causes flushing at the outlet (see Figure 7). The best placement of the deaeration section is just above the air permeation region. As the powder drops through the open cylinder bottom, it is re-entrained in the flowing powder below, which keeps holes within the cylinder from plugging. If upper and lower air permeation regions are used, it may be necessary to have a deaeration section in both regions. Generally, the deaeration section will have a pressure regulation device set at approximately the same pressure as the air permeation unit.

Screw feeder. Such a feeder can provide continuous feed without introducing additional air and can also

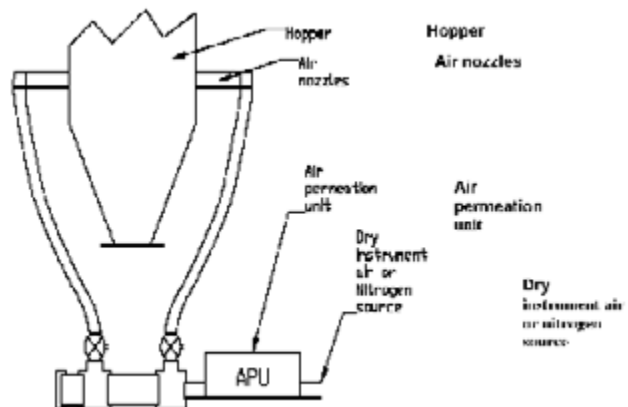

Figure 4. Air permeation systems replace air lost when powder compresses.

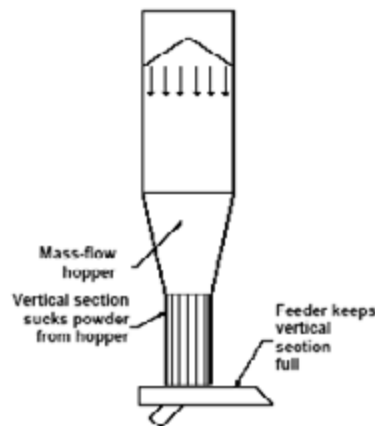

Figure 5. A vertical pipe installed below the hopper can increase flow.

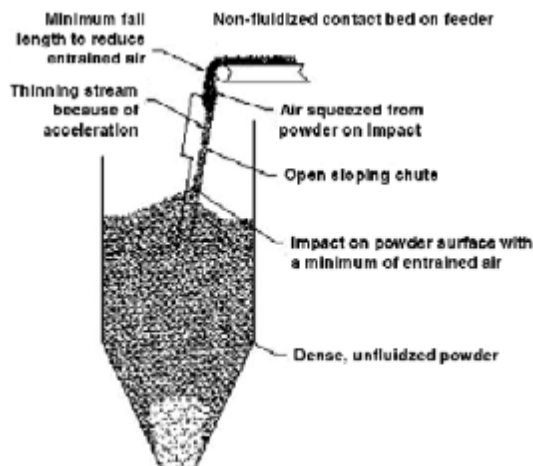

Figure 6. A sloping letdown chute is an inexpensive retrofit.

seal against air pressure in the hopper, provided the hopper is properly designed. It can also deaerate powder by squeezing excess air from the compacted material.

In some cases, installing a compacting screw above the hopper to remove air before the powder enters the hopper will work. However, this still requires an open let-down chute to provide surface contact for the descending powder to prevent re-aeration. One design includes a weighted flap plate and air disengaging section that seals against most pressures generated by collapsing ratholes.

Hopper retrofits. If a hopper does not produce flow at the hopper walls (commonly called mass flow), retrofitting the existing hopper can eliminate the source of flushing while improving segregation, process flow rates and feeder performance. Although a more expensive option, it is often the most reliable and cost-effective in the long run.

Retrofitting a conical bin outlet with a properly sized small hopper that produces flow along hopper walls or with a small cone-in-cone hopper (see Figure 8) allows a high flow rate without flushing. The retrofit must be large enough to eliminate ratholes (flow channel greater than the critical rathole diameter) but small enough to prevent powder over-compaction in the flow channel.

A one-dimensional convergence hopper (Figure 9) reduces flushing potential by increasing the solids' contact pressure at the outlet to about two times that of a two-dimensional conical hopper. This increased pressure allows powder flow without excessive voids' expansion, thereby reducing the air vacuum created when voids expand. Reducing the vacuum can double or triple the flow rates.

Other solutions include:

- keeping the solids' level high in the bin;
- reducing bearing purge pressure as low as possible or replacing an air purge seal with a packing gland where possible;
- venting rotary valves both on the high-pressure return side and at the level where powder enters;
- maintaining rotary valves to minimize air leakage;
- eliminating air pads; and
- introducing process gas higher in the hopper to allow powder below to pressure-seal the hopper.

SUCCESS STORIES

Let's now look at a couple of actual flushing problems and how they were solved.

Fly ash typifies the bimodal flow rates that can occur

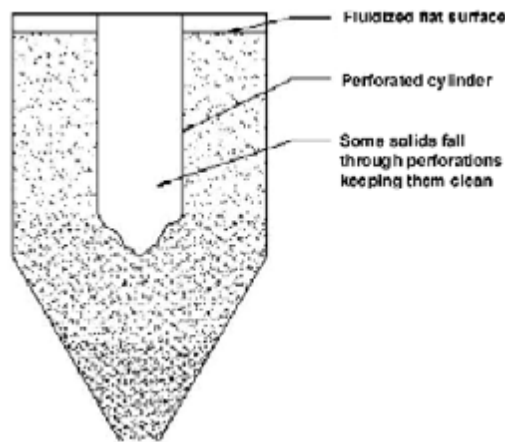

Figure 7. Deaeration cylinder will remove excess air before it causes flushing at the outlet

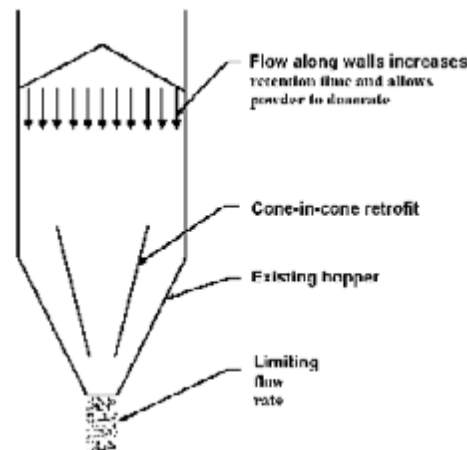

Figure 8. A cone-in-cone retrofit allows a high flow rate.

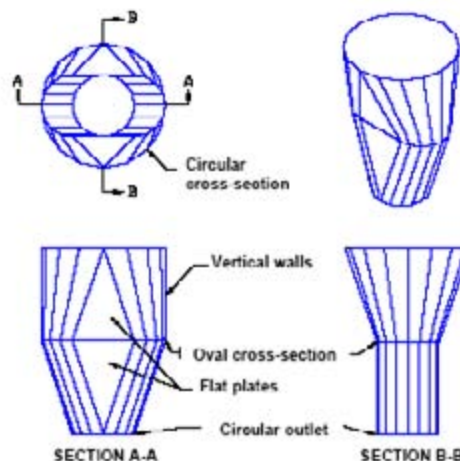

Figure 9. One-dimensional convergence can double or triple flow rates.



with fine powder. With entrained or injected air, fly ash flows like water but, when deaerated, it hangs up. Unfortunately, too much air injection causes uncontrolled flow that oscillates from extremely slow or no flow to sudden flushing, and too little air limits the rate.

A company stored fly ash in a 26-ft-diameter bin equipped with a 12-ft-diameter vibrated hopper that fed into a vibratory feeder and from there into a 40-ft-long conveying screw. A rathole frequently formed above the vibrated hopper in one or two quadrants and then collapsed, flushing more than half the fly ash in the bin through the conveying screw and into an adjacent building. This caused a cleanup nightmare.

The company solved its problem using a one-dimensional convergence hopper retrofit equipped with an air permeation system to condition the fly ash and provide controlled, consistent flow. The retrofit hopper was mounted to the lower half of the vibrated hopper, just below the interior baffle. In effect, the one-dimensional convergence hopper with air permeation replaced the vibrating feeder by sending material directly into the conveying screw. This arrangement increased the flow channel and fly-ash retention time in the flow channel to prevent rathole formation.

Cement is another example of a material susceptible to limiting and erratic flow rates. When stored in a bin, it consolidates under its own weight and, when discharged, expands near the outlet, creating an extremely low flow rate, which is often misidentified as an arching condition.

A company that transported cement from barges

to shore-side silos used a clamshell crane to unload the cement from the barge to an outside gravity-flow surge hopper that fed twin blow tanks. Because dustiness was a major concern, the crane operator lowered the clamshell to the top of the cement in the surge hopper before depositing his load. Unfortunately, this action compressed the cement, leaving it in a totally deaerated state, pressurizing some of the air trapped in voids between particles and dispersing some of the air from the top of the bin. As the cement was discharged and began to flow, the air entrained in the cement expanded. This reduced the air pressure to less than atmospheric, so air from outside the hopper outlet rushed in to fill the voids, creating an upward force that retarded flow.

The recommended solution was a one-dimensional convergence hopper with controlled air injection. Compared to a conical or two-dimensional hopper, the new unit doubled solids' contact pressures at the outlet, which allowed cement flow without excessive voids expansion. A vertical section was added between the hopper outlet and feeder to provide additional suction, which completely eliminated any vacuum at the hopper outlet. As a result, the company increased its cement flow rates by more than an order of magnitude.

As these examples show, you can prevent fine powder flushing.

LEE DUDLEY is president of Diamondback Technology, Atascadero, Calif. E-mail him at ldudley@diamondbacktechnology.com.

Vac-U-Max Introduces Bulk Bag Discharger

Units are specifically designed for semi- to non-free flowing powders.

VAC-U-MAX HAS introduced its new Bulk Bag Discharger designed for pneumatic conveying systems. The Bulk Bag Unloader provides a clean and efficient way to discharge the entire contents of a bulk bag and is specifically designed for semi- to non-free flowing powders.

Vac-U-Max Bulk Bag Dischargers use pneumatically operated massage paddles, operator access door for a complete sealed system, dust collection port, heavy-duty tubular frame, motorized hoist and trolley, screw discharger for controlled metering of powders into the convey line or process.

For more information, visit www.vac-u-max.com.





(800) 652-2466 or
www.fedequip.com

Pharmaceutical, Chemical, and Plastics Manufacturing Equipment

Federal Equipment Company has more than 50-years experience in the processing equipment industry, providing quality used equipment, outstanding service, and competitive prices to chemical, pharmaceutical, plastics, and related process industries. Major markets include API, speciality and fine chemical, bulk chemical, and pharmaceutical and biopharmaceutical manufacturing, including solid dose, liquids, powders, aseptic filling, and packaging.

In addition to thousands of pieces of equipment in stock and ready to ship, Federal Equipment offers specialized services including the liquidation and auction of process lines and manufacturing facilities, equipment appraisals, rigging, testing, and auction services, as well as managing the negotiated liquidation of surplus equipment.



Your Source for
Pfizer Surplus Equipment

Federal Equipment is your source for Pfizer process and packaging equipment. Go to fedequip.com and check out the latest additions to our inventory from Pfizer sites around the world.

Buy the best, from the best!

- Blister Lines
- Bottling Lines
- Capsule Fillers
- Centrifuges
- Coating Pans
- Dryers
- Filters
- Fluid Bed Dryers
- Fluid Bed Granulators
- High Shear Mixers
- Lab Equipment
- Mixers
- Tablet Presses
- Tanks
- Roller Compactors



39" APV Pilot Spray Dryer, S/S



10 Liter Gea Collette Nv High Shear Mixer, Type Ultimagra 10, 316 S/S

Contact Us At 1.800.652.2466 or by Email at deal@fedequip.com to get a Fast Quote.
View Our Entire Inventory Online at www.fedequip.com

8200 Bessemer Ave. • Cleveland, Ohio 44127 • T (800) 652-2466
www.fedequip.com • deals@fedequip.com



A Q&A on Horizontal Motion Conveying

By Matt Mayo, Tim Talberg, and Paul Cichanowski, Triple/S Dynamics

THE DIFFERENTIAL motion conveyor, also known as horizontal motion conveyor, induces a slow-advance/quick-return action. The key to differential motion conveying is the sliding action of the conveyor upon the inertia of the conveyed material. During the slow advance of the conveyor's cycle, material is at a relative rest on the conveying surface. The quick return segment of the conveyors cycle gently slides the conveying surface under the material bed, akin to pulling a tablecloth out from under a table setting. Continually repeating this cycle serves to smoothly convey the material up to forty feet per minute along the length of the conveying surface. This unique action gives differential motion conveyors the ability to convey all types of product from polymers to potato chips, hot potash to hot dogs, quicklime to cookies, breakfast cereal to borax crystals, or salt to scrap steel. This article answers many of the questions asked about horizontal motion conveying.

CAN THESE CONVEYORS BE EASILY CLEANED?

With cleaning and sanitation issues being of utmost importance to many processors, this question comes up a lot. The typical horizontal motion conveyor consists of a one-piece formed trough (or pan) section with suspension points spaced periodically along the conveyor pan length. This allows both the interior and exterior surfaces of the conveyor pan to be easily accessed for wipe down cleaning. There are typically no support frames or springs under the conveyor to clean, which introduces cracks and crevices that are very difficult to clean. The gliding of the product along the seamless one-piece formed conveyor pan discourages build-up of materials on the surface. The continuous sliding action on the conveyor's surface typically scours the pan clean so there's less time required between production cycles for cleaning.

CAN THESE CONVEYORS HANDLE A HEAD LOAD /FULL HOPPER?

Yes. Very large or heavy loads can be discharged this



way in a properly designed system. The horizontal motion conveyor has tremendous load carrying ability, with some units able to convey two to three times their own empty weight.

And because it is not a "tuned" system, the horizontal motion conveyor can be operated at variable speeds for control of the material travel rate. These conveyors are not "de-tuned" by typical increases in material loading on the pan of the conveyor.

WILL THESE TYPES OF CONVEYORS METER PRODUCT?

When arranged with a full hopper, the conveyor will vary its discharge rate according to the motor speed. The ability of the differential motion conveyor to convey deep product bed loads allows it to be used as a self-discharging storage unit.

The differential motion conveyor can also be equipped to provide for product aligning, singulating or product de-shingling. A food processor mak-



ing chocolate covered pretzels had to use several line workers to manually align and de-shingle product downstream from a regular vibratory conveyor that was shingling the pretzels due to the vertical pitching motion. When a horizontal motion conveyor was installed equipped with aligning lanes and special de-shingling ramps, the processor increased productivity and reduced the required manual labor by significantly reducing the number of shingled pretzels that resulted in scrap, therefore increasing line yields and reducing labor costs.

Also, the conveyor pan discharge can be equipped with pneumatically actuated product dams or manually adjustable flow baffles to accumulate and meter product to other downstream equipment.

CAN THESE TYPES OF CONVEYORS BE TOTALLY SEALED?

The unique conveying action of this type of conveyor will allow the use of either mated sliding surfaces between conveyors or the use of the standard flexible boot type inlet/outlet connections. A tube type conveyor allows a sealed and separate chamber open to the upstream and downstream process. The conveying section can be a fabricated trough or enclosed tube. If you must isolate your material from your plant environment, whether it is to control dust, provide pressure isolation, blanket the material with an inert gas, or to provide other environmental controls, you can select a totally enclosed tube. One or more feed inlets can be located anywhere along the conveying sections length; each is typically sealed with a flexible boot to control dust. Cleanout ports can also be added along the length of the conveyor.

ARE THEY ENERGY EFFICIENT?

In terms of energy consumption, horizontal motion conveyors are very competitive with roller belts, natural frequency and drag type conveyors. They use less than slider belts, and substantially less than screw conveyors. The motor is sized to start the drive, and typically only experiences full load power draw when starting. For most products, the motor runs at 50% or less of rated capacity. The case of deep beds of very heavy conveyed materials, like scrap steel or castings, is the exception, where increasing material loads increase the motor's amp



draw. For most materials, the motor load is independent of the amount of product conveyed.

WHAT ABOUT HIGH OR LOW TEMPERATURES?

The differential motion conveyor is a highly adaptable piece of equipment suited well for virtually every industry. These conveyors can be operated in a wide range of extreme temperatures.

In certain applications, air or water cooling systems have been used with horizontal motion conveyors to reliably handle materials up to 1700°F.

WHAT IF MULTIPLE INLETS AND DISCHARGES ARE REQUIRED?

More than one inlet and discharge can be incorporated into a single conveyor. The discharges can be a preset ratio of flow, variable discharge amounts or an "all or none" to different discharges. It is also possible to create an inventory of material before each discharge for an immediate delivery during demand.

One or more discharge outlets can be located at any of the various points along the conveying section's bottom to distribute the material. Each outlet can be fitted with a mechanical discharge gate to start and stop material discharge. These gates, typically pneumatically actuated, can be a sliding style gate, butterfly valve or tip style drop gate.

Multiple inlets can be used to introduce product from different storage devices or to meter in a mixture of materials into one conveyor. This type of conveyor will not stratify or blend these materials to ensure a uniform discharge.



Multiple lanes can also allow different products/materials to be conveyed using the same conveyor pan and a single drive unit. Products will remain separated on the conveyor. In a recent application, several sizes of the same type of products were run in the single conveyor pan.

WILL ABRASIVE MATERIALS CONVEY ON THE DIFFERENTIAL MOTION CONVEYOR?

By the same nature of gentle handling of fragile products, tough/hard or abrasive materials do not impact or wear the conveyor pan surfaces at high rates. The differential motion of the conveyor does not press the material into the pan, forcing a gouging action that will wear the pan surface faster unlike vibrating conveyors. Abrasive wear is two to four times less than a conventional vibratory conveyor.

Recently, an industrial minerals producer had an application handling abrasive construction sand. Their major concerns were dust control and downtime due to regular vibratory conveyor maintenance because of the abrasiveness of the product. A differential motion conveyor was designed with BHN 400 abrasion resistant conveying troughs, fully enclosed with integral dust covers. This conveyor showed an average surface wear of just 0.010 inches after 14 months of operation. Dust emissions were eliminated and the only maintenance required is periodic lubrication.

In another abrasive application, a ceramic parts producer had a different problem. The dust generated from a cutting process was causing their existing belt conveyor bearings to fail quickly. Access to the bearings which ran the length of the belt conveyor was difficult and cumbersome. When this belt conveyor was replaced with a differential motion conveyor, with the drive unit at one end, moving parts of the unit were not exposed to the dust loading and are now more easily serviced at normal maintenance intervals.

If the conveyed materials are corrosive in nature, like chlorinated bleach powder, a titanium conveying trough may be one solution.

CAN MOIST OR STICKY PRODUCTS BE CONVEYED ON THE DIFFERENTIAL MOTION CONVEYOR?

If the material to be conveyed is sticky, like dish-washing detergent, a conveying trough made of ultrahigh-molecular-weight polyethylene (UHMW-



PE) will prevent sticky particles from adhering to the surface. This type of conveying surface lends itself to reduced product adherence and allows expeditious of the cleaning process.

Materials with a high surface tension, like raw meats or cheeses, may be conveyed using textured stainless steel conveyor pan materials.

HOW LARGE AND ROBUST CAN THE CONVEYORS BE?

Conveying lengths of over 200 ft and pan widths of 8-10 ft have been in use for many years. Massive impact loads and carrying capacities can be achieved with the use of structural trusses and impact beds. Pan construction of AR plate 1-inch thick and above is commonplace for the harshest conveying environments. Hundreds of these differential motion conveyors are at work today moving scrap steel, some conveyors as wide as 8 feet with an empty weight of over 300,000 pounds.

MATT MAYO, Product Manager – Industrial Applications, **TIM TALBERG**, Product Manager – Food Applications, and **PAUL CICHANOWSKI**, Product Engineer – Food Applications, all with Triple/S Dynamics, contributed to the above article. Their combined 50 plus years of experience with horizontal motion conveying applications and the real questions asked by processors were the basis of the article.

"Go Long"

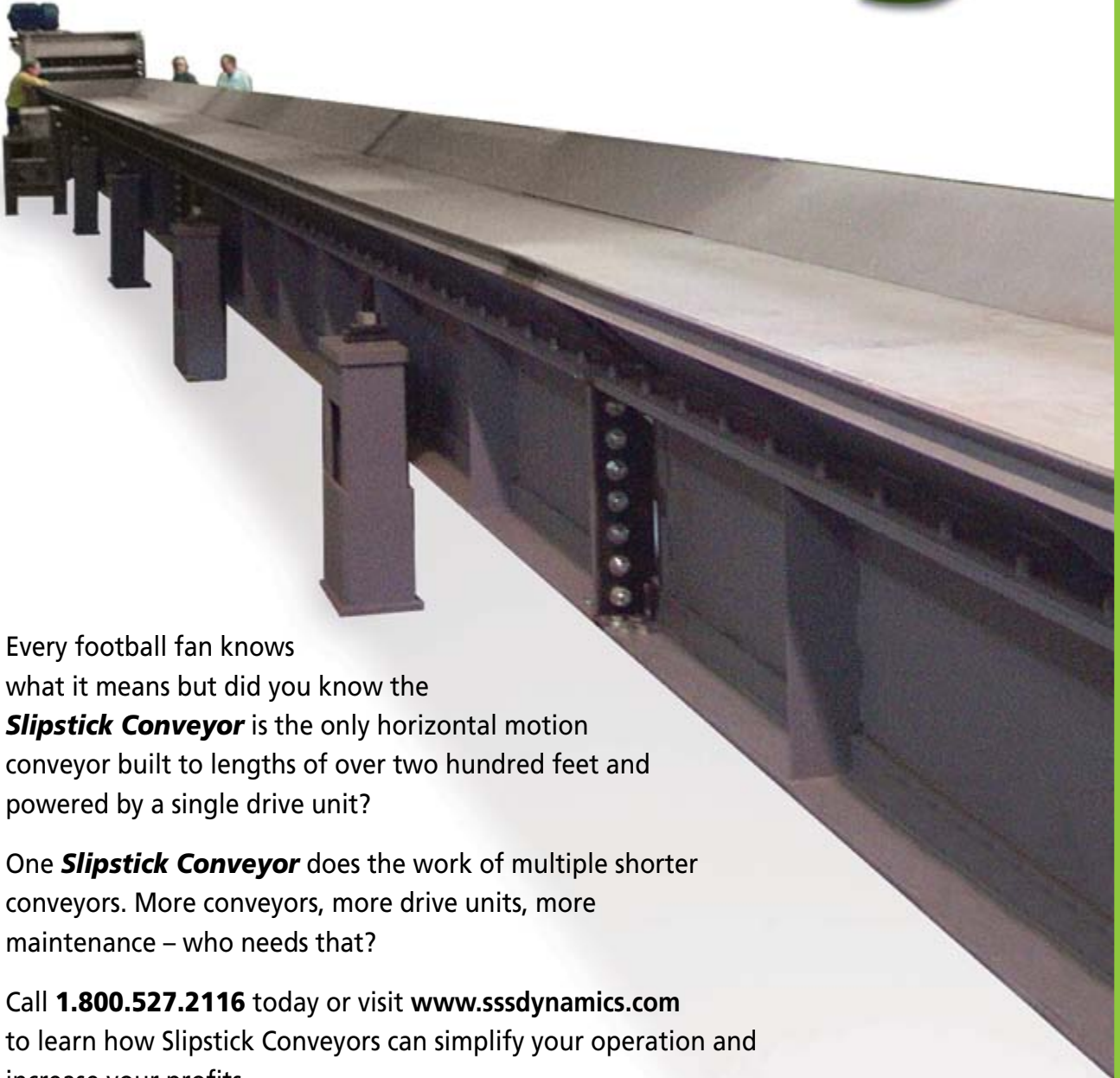

Every football fan knows what it means but did you know the **Slipstick Conveyor** is the only horizontal motion conveyor built to lengths of over two hundred feet and powered by a single drive unit?

One **Slipstick Conveyor** does the work of multiple shorter conveyors. More conveyors, more drive units, more maintenance – who needs that?

Call **1.800.527.2116** today or visit www.sssdynamics.com to learn how Slipstick Conveyors can simplify your operation and increase your profits.

*When size matters,
Slipstick Conveyors go the distance.*



Triple/S Dynamics, Inc.

www.sssdynamics.com

1.800.527.2116

P.O. Box 151027 • Dallas, TX 75315-1027



Tubular Drag Conveying Technology

Bottle-grade PTA resin manufacturer finds an energy and cost saving alternative to pneumatic conveying.

By Joe Zerbel, Hapman Product Manager

FACED WITH tight profit margins in an ever-increasingly competitive market, many manufacturers are taking a closer look at creating an even leaner manufacturing process. Understanding conveying technology can have a significant impact on both energy costs and the overall efficiency of the process.

The analysis of the optimal conveying method begins with understanding system and material variables such as; energy requirements, bulk density of material, purchasing and storage of material prior to use, conveying distance, space and location, and durability and maintenance. These are just a few of the many elements that must be considered in conveyor selection and design.

Pneumatic conveying is often a standard solution for processing facilities conveying dry bulk product. While pneumatic conveying has advantages in specific applications, a totally enclosed tubular drag conveyor can offer similar advantages, while also providing:

- Custom engineered designs that meet specific plant layout requirements, inlet and discharge points and flow rate.
- Gentle conveying of highly degradable materials, yet durable for mineral and mining material handling.
- Minimal operator monitoring with patented air-over-hydraulic auto tensioner that automatically maintains chain tension for reliable and consistent flow

Figure 1. The Hapman tubular drag conveyor is constructed of 8-inch (200-millimeter) stainless steel casing and employs three inlets and one outlet, as well as a discharge vibrator to ensure 100% discharge of PTA powder. A low-horsepower (25 HP) motor moves a stainless steel chain with polyethylene flights throughout the conveyor's 325-foot (99-meter) circuit to a final discharge height of 115 feet (35 meters) at a 79-degree incline. The continuous operating conveyor moves 883 cubic feet (25 cubic meters) of PTA powder per hour.



- Variable frequency drives that mitigate energy usage spikes and reduce overall power requirements.
- A fully enclosed conveying system that does not introduce air into the material stream, reducing the chance of igniting dust.
- Low energy consumption.

PET RESIN MANUFACTURER SAVES ENERGY AND IMPROVES PRODUCTION WITH TUBULAR DRAG TECHNOLOGY

As an example of these benefits, Dhunseri Petrochem & Tea Ltd. (DPTL) had a goal to significantly reduce costs by replacing pneumatic conveyors with tubular drag technology. Located in Haldia, West Bengal, India, DPTL is a leading global manufacturer of bottle-grade PET (polyethylene terephthalate) resin. The lightweight and recyclable PET uses purified terephthalic acid — more commonly known as PTA or TPA — as its main component. The resulting PET product is sold to manufacturers for use in making plastic bottles for packaging drinking water, carbonated soft drinks, and other beverages.

The DPTL facility produces 600 metric tons of PET resin per day, and runs the pneumatic conveyors year round transporting PTA from 15-ton hoppers to a staging silo 115 feet (35 meters) above ground at a rate of 883 cubic feet (25 cubic meters) per hour. The pneumatic conveying system was operationally effective; however the system's nitrogen compressors consumed a large volume of energy, dramatically increasing operating costs and reducing profits.

Charged with improving efficiency and decreasing operating costs, DPTL executives researched a more economical solution to pneumatic conveying. The results of their research lead them to tubular drag conveying technology. This rugged, low velocity conveying method required virtually no maintenance, reduced noise levels in the plant, and consumed little power.

“Our original process relied upon pneumatic conveyors to move PTA powder,” said Subrata, Mazumdar, Senior general manager of engineering for DPTL. “The pneumatic conveying system, which relies on gas compressors to operate,

Figure 2. “We’ve achieved our goal of reducing energy and nitrogen consumption when conveying PTA by replacing the 167.5 kW pneumatic conveyor with a 33.5 kW tubular drag conveyor.”

— Subrata Mazumdar,
Senior general manager of engineering for
Dhunseri Petrochem and Tea Ltd.

consumed an enormous amount of energy and nitrogen.”

By replacing the 167.5 kW pneumatic conveyors with 33.5 kW (25 horsepower) tubular drag technology, DPTL reduced energy consumption by 134 kW, and nitrogen consumption by 2,500 Nm³ per day.



TUBULAR DRAG CONVEYOR TECHNOLOGY

The tubular drag conveyor consists of a stationary outer housing, usually round in shape, through which a chain is pulled by a sprocket drive. Flights are attached to the chain at regular intervals. As the looped chain and flight assembly moves through the stationary housing (see Figure 3), bulk material is pulled from the in-feed points to the discharge ports.



Figure 3. Tubular drag conveyor chain and flight assembly shown in a clear casing.

Conveying capacity is established by varying the housing size, distance between flights, and the chain speed. The stationary outer housing, or casing, is manufactured of carbon steel or stainless steel pipe in sizes ranging from 3-inch (76-mm) diameter up to 12 inch- (304-mm) diameter. Figure 4 represents the intersection of optimal size and flow for effective movement of material. Casing sections are supplied in lengths as required by the predetermined conveyor path. To provide for a change in direction, the casing is formed into a sweep elbow.

All sections are constructed with bolted and gasketed flanged ends to allow for easy plant installation while assuring a tightly sealed system. Solid circular flights are available in polyurethane, ultrahigh molecular weight polyethylene,



cast iron, ductile iron, nylon, stainless steel or other material as required. Link and pin type chains are less prone to fatigue, wear and stretch than steel cables or ball-and-sprocket bar type chains. Round-link, rivetless and seal-pin chains are the most common types (see Figure 5.) The tubular drag chain and flight configurations



Figure 5. Tubular drag chain and flight options.

are selected based on specific application data for optimal performance.

Product discharge points are engineered where needed in the conveyor layout. The discharge gates, like the chain and flight assembly configurations, are important conveyor design considerations.

Traditional knife or slide gate valves are sometimes used in tubular drag designs but are not the most effective design for the application.

A conveyor discharge designed with a traditional gate valve requires a flat surface to seal against a cylindrical surface, resulting in an internal gap. This gap will cause several undesired issues during operation. As material moves over the discharge port, it accumulates in the space left by the shape difference between the two surfaces. This characteristic is true when the valve is in the open or closed position; product will never completely discharge from the gap. If the material is friable, a sheering affect begins to take place causing product degradation. Conveying applications such as mining and mineral processing will have failure issues related to the conveyed material characteristics. The large size and hard particle material moved in these applications, combined with the lack of full product discharge, will cause the gate valve to periodically fail to open because the carry over will become lodged in the valve path. Furthermore, in batch applications, the carry-over will cause cross-contamination of product. For these reasons, a

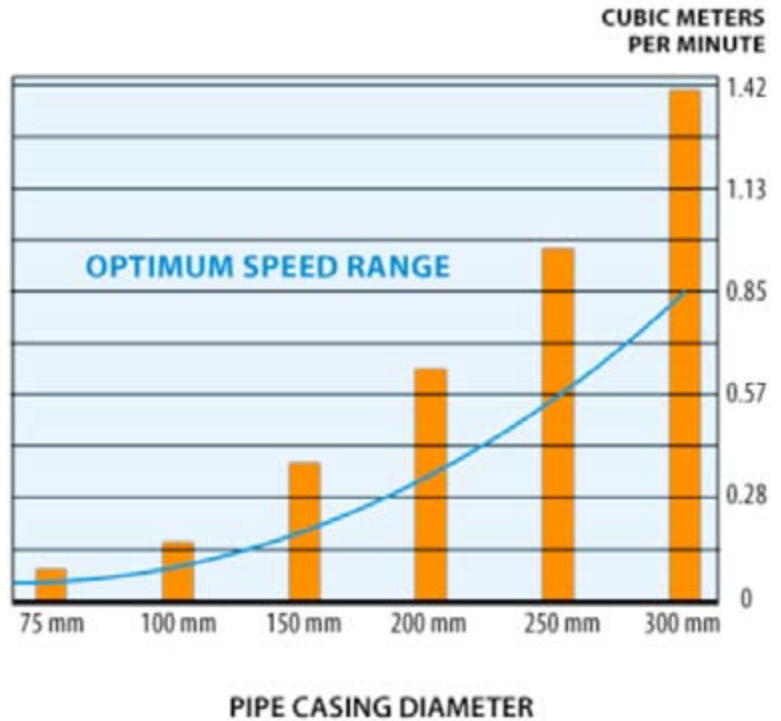

Figure 4. Average tubular drag capacity chart.



Figure 6. This full discharge gate valve features a convex valve design rather than flat, providing a tight seal to the conveyor with no internal gap.

discharge gate specifically engineered for tubular drag conveying is highly recommended.

Figure 6 shows a discharge gate specifically designed for tubular drag conveyors. The valve design is convex rather than flat, providing a tight seal to the conveyor with no internal gap. This design allows for 100% material discharge



when the valve is open, eliminating concerns of valve failure due to particles lodging in the valve path, or cross-contamination in batch applications. The pneumatically-operated actuator automates the valve operation and provides an optional integration into process control management software through a PLC.

TUBULAR DRAG CONVEYOR LAYOUT

By virtue of the flexible chain and the custom made conveying sections and casing bends, virtually unlimited variations of conveyor layouts are possible. An example of customized design configurations is shown in Figure 7. This type of conveyor can be installed in existing facilities, bypassing obstacles that would interfere with the path of other types of conveyors.

ENCLOSED, VERSATILE CONVEYING METHOD

A beneficial feature of this conveyor is the enclosed construction. This design effectively protects the product being conveyed from contamination from the outside atmosphere and/or protects the atmosphere and the worker from the product.

Material can be conveyed under a positive pressure or a purge blanket of inert gas. This operating condition usually exists in applications where the conveyed material is highly absorbent and cannot have moisture or air introduced in the conveying flow. It also applies to applications where material may oxidize and cannot have air entrained in the material flow. For these situations, an inert gas is used to pressurize the system at 44 psi (.017 bar).

The moderate moving, positive displacement action of the conveyor chain assembly makes the system ideal for handling blended materials without separation and assures gentle product handling with minimal product degradation. This measured movement also assures long conveyor life, plus dependable service and operation at minimal noise levels.

In addition, the rugged construction allows for conveying of hard and abrasive material in physically challenging environments. This system is designed to operate 24 hours a day, seven days a week under various loads.



Figure 7. A tubular drag conveying design provides plant and process engineers the ability to configure the conveyor layout as part of a complete material handling system.



Figure 8. In this lime milling and blending system a tubular drag conveyor helps deliver the final product to a truck loading station..

THE TUBULAR DRAG CONVEYOR SYSTEM INTEGRATION

The tubular drag conveyor flexibility provides plant and process engineers the ability to configure the conveyor layout as part of a complete material handling system. Figure 8 represents a



lime milling and blending system used in many chemical processing plants. In this application, several dry products are unloaded from bulk bags while a third product is conveyed from a storage silo. The raw material is brought to a loss-in-weight blending station which uses a metered feeder to accurately blend the mixture in preset ratios. The blended product is then discharged into a grinding mill for particle reduction and final blending. A tubular drag conveyor on the discharge of the mill delivers the final product to a truck loading station where it is hauled away for packaging or bulk sale.

CONVEYING WITH CONFIDENCE

The tubular drag conveyor is a viable alternative to pneumatic conveying offering many benefits in a wide range of applications. The core operating components of the conveyor allow for optimal conveying based on material and application factors. Particle size, bulk density, intermittent or continuous operation, volume of flow, number of

unique materials to be conveyed, and obstacles or barriers the layout must overcome are all important design criteria used in the engineering of a tubular drag conveyor. This technology is also very energy efficient in comparison to pneumatic conveying, especially when the compressor energy source is an expensive utility such as nitrogen.

The tubular drag chain and flight configurations, materials of construction, and number and placement of inlet(s) and discharge points, are customized elements of design. The tubular drag conveyor is typically shipped in sections with flanged ends for manageable in-plant installation.

The design options with the tubular drag conveyor allow for integration into a new or an existing material handling system and provide for long, reliable conveying operation.

For more information on tubular drag conveyors, please visit www.hapman.com, or contact **JOE ZERBEL**, Hapman Product Manager, at (800) 427-6260 (US/Can), or by e-mail at sales@hapman.com.

Bauermeister Introduces New Universal Mills

Seven production scale sizes and a lab size allow maximum grinding flexibility.

BAUERMEISTER USA has introduced a new universal mill with seven production scale sizes and a lab size, which allows maximum grinding flexibility from coarse to ultra-fine particle size reduction. Suited for applications such as pigments, resins, MAP, SAP and PVC, the universal mill works with four interchangeable rotors, including turbo, pin, disc and cross.

An option for all stainless steel construction allows the mill to be used with gases or liquids (e.g. CO₂, LN₂) to promote cooling and/or inertization. The lab-sized mill, ULD, enables accurate and reliable testing for product development, as well as small scale production runs in batch or continuous arrangements.

For more information, visit www.bauermeisterusa.com.



~~Impossible~~

In any process challenge, the difference between the possible and the impossible is knowledge. Put Hapman's 60 years of industry experience and material handling knowledge to work for you and discover the possibilities.



Helix® flexible screw conveyors



MiniVac™ vacuum conveyors



Tubular drag conveyors



Bag dump stations



PosiPortion™ feeders



Bulk bag unloaders



Bulk bag fillers



www.hapman.com
Toll Free: 800.427.6260

HAPMAN.
Ideas that move™

Hapman World Headquarters, 6002 East Kilgore Road, Kalamazoo, Michigan 49048 USA



This is Not “Dust” So I Don’t Have a Problem!

By Ashok G. Dastidar, Dust & Flammability Testing Laboratories, Fauske Associates, LLC

THERE HAS been a great deal of interest in the field of combustible dust explosion/fire protection since the Port Wentworth, GA sugar dust explosion that occurred at Imperial Sugar. There have been several U.S. Chemical Safety Board reports on the subject of dust explosions and the Occupational Safety and Health Administration (OSHA) has issued a national emphasis instructing auditors about how to assess a dust explosion hazard. Additionally, there has been renewed interest in the activities of the National Fire Protection Agency (NFPA) with regard to combustible dust fire and explosion risk mitigation standards. These agencies are addressing issues such as dust explosion venting, dust explosion suppression, fugitive dust clean up, combustible dust hazard classification zones, etc. In all cases they are addressing “dust” hazards, but what is a “dust”? The NFPA 654 defines it as finely divided particles that can be dispersed in the air.

Other NFPA standards define it as particulates with particle size limitations. For example; section 3.3.27.1 of NFPA 664-2012 “Standard for the Prevention of Fires and Explosions in Wood Processing and Woodworking Facilities” states that a deflagrable wood dust is wood particulate matter capable of propagating a flame that has a mass mean diameter of 500 microns or smaller. Then section 3.3.27.2 of the same standard states that dry nondeflagrable wood dust is wood particulate material that has a mass

median particle size greater than 500 microns. NFPA 664 is not alone in this type of narrow interpretation. Section 3.3.1 of NFPA 61-2008 “Standard for the Prevention of Fires and Dust Explosions in Agricultural and Food Processing Facilities” states that agricultural dust is any finely divided solid agricultural material 420 microns or smaller in diameter that presents a fire or explosion hazard when dispersed and ignited in air. Even OSHA defines combustible dust as flammable particulate material less than 420 micron. The rationale being that particles greater than 420-500 microns do not pose a threat of an explosion. From first-hand experience in operating a testing laboratory, we know that this is not true.

This article will present some data from experiments conducted in a 20-L Siwek chamber and spherical 1-m³ chamber that demonstrates the explosibility of combustible dusts that have a mean particle diameter greater than 500 microns. This information is discussed in greater detail in a presentation authored by Erdem Ural, Stuart Johnson, and Ashok Ghose Dastidar titled “Effect of Particle Shape and Size Distribution on Dust Explosion Risks” and delivered at the 8th Global Congress on Process Safety, from April 1-5, 2012 in Houston, TX.

One of the “dusts” selected for this study was wood dust purchased from American Wood Fibers. Two grades were selected to provide distinct particle size distributions. The first was a fine material – Grade

SAMPLE	MEAN DIAMETER	DIAMETER ON %			MOISTURE WT%
		10%	50%	90%	
Grade 14020 “Wood Flour”	59.5 µm	11.5 µm	53.3 µm	114.8 µm	1.57
Grade 2020 “Wood Dust”	836.8 µm	458.9 µm	787.0 µm	1272.5 µm	3.85

Table 1. Particle size distribution of test samples



14020 — which will be referred to as Wood Flour; and the second was a coarse material — Grade 2020 — which will be referred to as Wood Dust. The wood dust material was sieved to remove the fraction of particles that were between 500 μ m and 850 μ m for testing. The particle size distribution information is presented in Table 1. The wood flour is very fine with a mean particle diameter of approximately 60 μ m. The wood dust is very coarse having a mean diameter of approximately 840 μ m; this material can even be considered as “nondeflagrable wood dust” per the NFPA 664 standard.

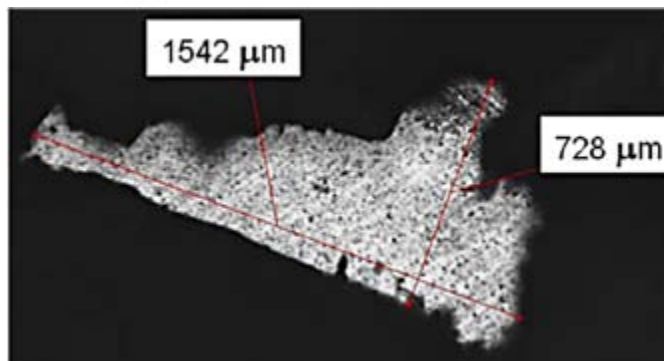

Table 1. Particle size distribution of test samples.

It is important to note that even though the wood dust was sieved material, there might still be particles which have elongated morphologies so the short axis may be less than 850 μ m, allowing the particle to pass through the sieve, but the long axis may be much greater than the screen opening. Figure 1 is a micrograph of the type of particle which would have passed through the sieve.

These two materials were used as the source samples for various mixtures used for explosion severity tests that were performed. The wood flour mixtures with 0%, 50%, 80%, 90%, and 95%. Wood dust mixtures were tested in addition to 100% wood dust.

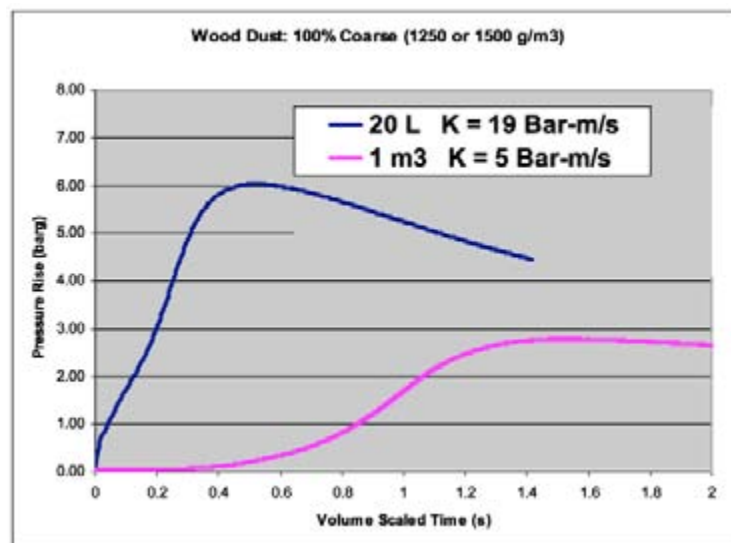

Figure 2. Pressure-time traces of 100% wood dust deflagration tests.

To establish the explosibility of the wood mixtures, test method ASTM E1226-10 “Standard Test Method for Explosibility of Dust Clouds” was selected to be performed in both chambers to ascertain explosion severity. In this method, a pre-weighed dust mixture is dispersed into the combustion chamber with compressed air creating a confined cloud of “dust”. Then after a preset delay, two 5-kJ igniters are discharged and the resulting pressure rise from the combustion of the cloud is recorded as a function of time. This process is repeated with increasing quantities of dust until a maximum value has been found for the explosion overpressure and the maximum rate at which the explosion progresses. According to ASTM E1226, dusts deflagrations producing P_{max} greater than 1 barg are explosible. An example of a typical pressure-time trace is presented in Figure 2 below.

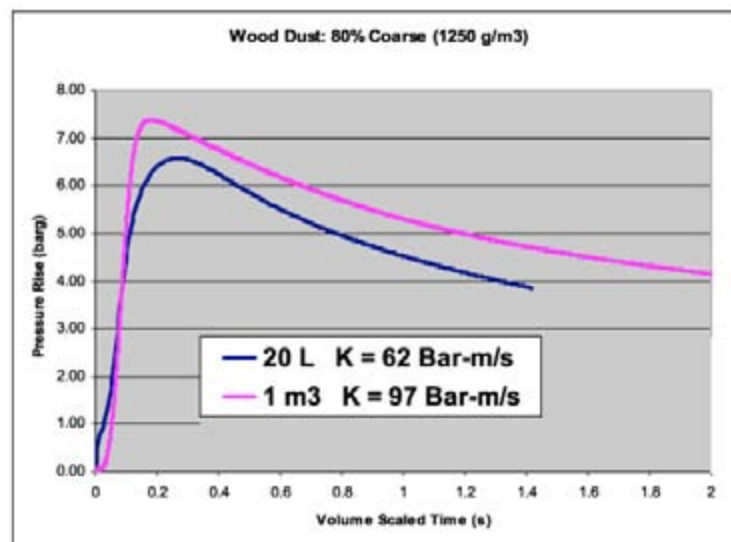

Figure 3. Pressure-time traces of 80% wood dust deflagration tests.

In Figure 2 the test data is plotted for 100% coarse wood dust in both the 20-L chamber and 1-m³ chamber. The explosion overpressure, expressed in barg, is plotted on the ordinate with the volume-



scaled time, in s/m, on the abscissa. The results from the 20-L chamber (blue line) indicate that the deflagration resulted in a 6 bar overpressure with a 19 bar m/s rate of pressure rise. Additionally, the 1-m³ data (pink line) indicates that the deflagration in that chamber produced an overpressure of 2.8 bar and a rate of pressure rise of 5 bar m/s. It is important to note that the dispersion mechanism on the 1-m³ chamber was designed primarily to disperse very fine dust having a particle size less than 65µm. As a result, slow burning of dust clouds at high dust loadings with coarse material may be expected. The important factor to note is that material, according to some NFPA standards, that should not be capable of supporting flame propagation, appears to do so very well.

As the coarse wood dust is “contaminated” with fine material (adding 20% wood flour to wood dust) the explosion severity measurements in the two chambers become similar, as seen in Figure 3. Both chambers produced peak overpressures in the range of 7 bar and had comparable rates of pressure rise. A comparison of the peak overpressures and rates of pressure rise are made in Figures 4 and 5 respectively where the data is plotted as a function of percent coarse wood dust in the mixture. As in the previous figures the wood flour/wood dust mixtures are explosible for all samples tested.

The test data clearly demonstrates that “non-deflagrable” wood dust as defined in NFPA 664 is actually an explosion hazard and that even a small amount of contamination with wood fines (wood flour in this case) is capable of making weak explosions energetic. Similar deflagration results were observed in the 1-m³ and 20-L scale for various dusts mixtures tested, thereby, putting to rest the very dangerous myth that coarse wood particles having a mean particle size greater than 500 micron do not pose a dust explosion risk.

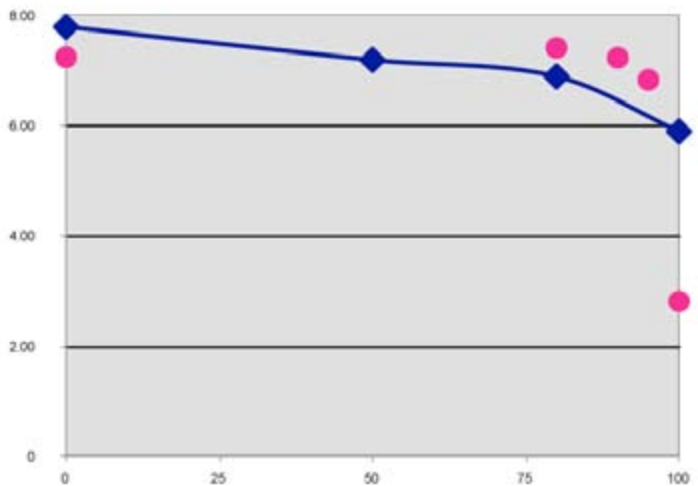

Figure 4. Explosion overpressure in the 20-L chamber and the 1-m³ chamber as a function of percent coarse wood dust in the mixture.

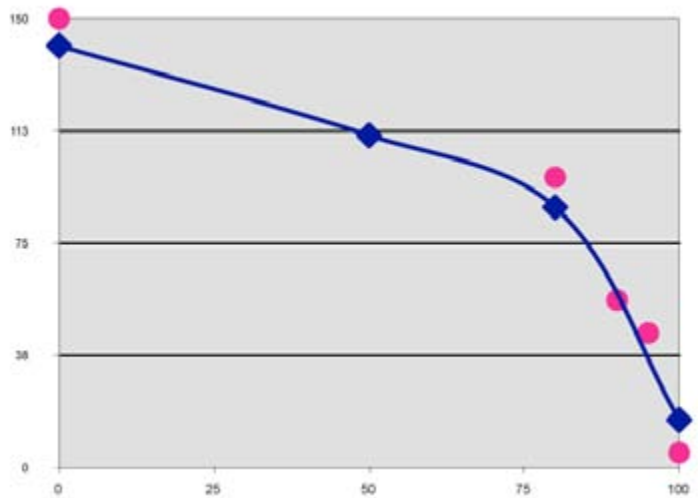

Figure 5. Explosion rate of pressure rise in the 20-L chamber and the 1-m³ chamber as a function of percent coarse wood dust in the mixture.

REFERENCES:

1. NFPA 664: Standard For The Prevention Of Fires And Explosions In Wood Processing And Woodworking Facilities
2. NFPA 61: Standard For The Prevention Of Fires And Dust Explosions In Agricultural And Food Processing Facilities
3. ASTM E1226 (2010) Standard Test Method for Explosibility of Dust Clouds
4. Erdem Ural, Stuart Johnson and Ashok Ghose Dastidar, "Effect of Particle Shape and Size Distribution on Dust Explosion Risks" 8th Global Congress on Process Safety, from April 1-5, 2012 in Houston, TX.



COMBUSTIBLE DUST TESTING & CONSULTING

***The leading testing lab
for 31+ years
ISO 17025 Certified***



**Combustible Dust Testing
Onsite and Desktop Dust Assessments
OSHA Process Safety Management (PSM)
Process Hazards Analysis (PHA)/
Layers of Protection Analysis (LOPA)
Violation/Inspection Assistance
Incident Investigation
Vent Sizing & Suppression
Mitigation System Design & Consulting**

**WWW.FAUSKE.COM
BURR RIDGE, IL +1877-FAUSKE1 INFO@FAUSKE.COM**

Cyclonaire Boosts Production, Reduces Spillage at P&G

Case History of the Procter & Gamble manufacturing plant in Vallejo, Mexico

By Joe Morris, V.P. Sales and Marketing at Cyclonaire Corporation

THE PROCTER & Gamble Co. manufacturing plant in Vallejo — the most established industrial area in Mexico City, Mexico — is a leading producer of dry laundry detergent, including popular Latin American brands Ariel®, Bold®, Safe®, and Rindex®. The Vallejo manufacturing plant is just one of Procter & Gamble's many global locations, including six other manufacturing sites and a corporate office in Mexico. Cincinnati, Ohio-based P&G boasts one of the largest and most profitable home, health, beauty, and food brand portfolios worldwide and employs nearly 140,000 workers in more than 80 countries. Other leading P&G brands include: Pampers®, Tide®, Always®, Pantene®, Bounty®, Dawn®, Pringles®, Folgers®, Charmin®, Downy®, Iams®, and more than 200 other names. Three billion times a day, P&G brands touch the lives of people around the world, according to the company.

The company's \$17.15-billion fabric-and-home-care business is one of P&G's key divisions — accounting for almost one-fourth of the company's total \$68.22-billion annual sales. Within that amount, laundry detergent — led by billion-dollar brand Tide — accounts for much of the year-after-year sales growth. According to the company, the average American woman spends seven to nine hours a week on laundry. Is it any wonder that detergent brands are a key component of the company's portfolio?

The P&G Vallejo plant, employing more than 1,000 workers, is one of the largest detergent manufacturing facilities in the world. Its soap is primarily distributed throughout Central America. The plant also pays special attention to the environment — ensuring that contamination and pollution are limited. As a result, the plant has reduced its water use and waste.

THE PROBLEMS

Handling more than 100,000 tons of sodium carbonate, or soda ash, annually doesn't come without a price for the Vallejo-based P&G plant. Plant manag-



Figure 1. A vacuum-loaded Cyclonaire HC-75 semi-dense phase conveyor (high capacity – 75 ft³ volume tank), with three material inlets, conveys materials at more than 25 tons per hour.

ers noted a decrease in efficiency and productivity, excessive air consumption, and costly maintenance as primary operational problems with its existing railcar unloading system. As it was, the system wasn't capable of conveying the necessary 25 tons per hour to achieve maximum productivity. Instead, just over 11 tons per hour were regularly conveyed — an immeasurable loss of opportunity and cost. The system was the obvious bottleneck — causing an interruption in material flow. The cost of staying with that system was an estimated three times more expensive, according to the plant.

Additionally, because of Mexico City's high elevation and low pressure, the plant's blower packages ran "hot" — requiring excessive electrical and air consumption that cost the company considerably. For instance, the blowers, which needed to be replaced every two years, cost \$15,000 annually in maintenance and replacement charges.

An efficient and dependable discharge system to transfer the sodium carbonate would reduce the risk

of interruptions; provide for a cleaner, automatic operation; and would eliminate the need for transferring material in inefficient ways. The company's new system requirements included:

- Increase the convey rate from the railcar to silo 10-15 tons per hour compared to the existing system.
- Improve efficiency of the equipment and the workforce.
- Eliminate downtime for downstream processes.
- Reduce maintenance costs.
- Increase profitability.
- Provide an automated system to unload the entire railcar without shutting down the system.
- Incorporate two storage silos with the installation of one highly dependable pneumatic conveying system.
- Overall improvement in convey rate, process reliability, simplicity of process, value, and consumption, while meeting installation and space requirements to ensure a trouble-free installation.

THE SOLUTION

York, Neb.-based Cyclonaire Corporation is a manufacturer of bulk material handling systems, specializing in pneumatic conveying. The company supplies components as well as complete dilute, dense, and semi-dense phase conveying systems. Its services range from concept engineering and project management through start-up supervision. Cyclonaire serves all types of industries engaged in handling powder, and has extensive railcar unloading experience. Pablo Suzuri, the plant manager at the P&G Vallejo plant, became familiar with Cyclonaire and its products, having read about the company in trade publications and visiting its website. Cyclonaire supplies semi-dense conveying systems, which are the optimum solution for medium rate transfer of abrasive or friable materials.

To improve efficiency, convey rates, and decrease air consumption, the P&G plant decided on a high-capacity HC-Series semi-dense phase pneumatic conveying system from Cyclonaire. This decision was reached after months of planning, a review of recommended equipment from manufacturer Cyclonaire, and site visits.

The HC-Series conveyor system was matched with Cyclonaire CycloLift™ railcar/truck connec-



Figure 2. Three Cyclonaire CycloLift™ railcar connectors were installed beneath the tracks to streamline rail unloading from the hopper-bottom cars and eliminate spillage.



Figure 3. A CycloLift™ railcar connector elevates the boot from between the tracks and mates it firmly against the hopper slide gate — replacing conventional hydraulically activated mechanical linkages with pneumatically actuated lifters.

tors, Air Shoot™ gravity conveyors, an intermediate-pressure (15 psig) blower package, a pinch diverter valve, and convey line — all of which are designed for semi-dense phase vacuum loading/pressure conveying and railcar/truck unloading. The new Cyclonaire equipment was installed by a local contractor at the P&G rail siding approximately 100 meters from two storage silos. The equipment is in constant use at the Vallejo plant.



THE ADVANTAGES

Prior to the installation of Cyclonaire equipment, P&G utilized an outdated mechanical bootlift style connection that was very cumbersome and leaked material at various locations from the connection. To remedy this problem, three Cyclonaire CycloLift Railcar connectors — one for each outlet on the three-hopper railcar — were installed to streamline rail unloading from the hopper-bottom cars and eliminate spillage that can contaminate the area. Versatile CycloLift connectors adapt to various railcar outlet sizes using a patented airlift system to allow for more flexible and efficient railcar unloading.

CycloLift connectors come with steel adapter plates that move longitudinally to speed alignment of the boot seal with the hopper slide gate and cut down on time-consuming railcar repositioning. To elevate the boot from between the tracks and mate it firmly against the hopper slide gate, the CycloLift connector replaced conventional hydraulically activated mechanical linkages with pneumatically actuated lifters. The lifters were located under the top plate that carries the resilient rubber gate seal. When extended, the lifters created a tight boot-to-gate seal regardless of the tilt of the railcar or irregularities in the gate surface. During unloading, it automatically maintains its seal with the railcar to eliminate leakage. Conventional mechanical devices may not mate properly if the hopper opening and the lift mechanism are not in the same horizontal plane. This likely causes product to leak – contaminating the area and resulting in material loss.

From the outlet of each of the three CycloLift connectors, a 12-inch, dust-free Cyclonaire Air Shoot fluidizing conveyor was installed to serve a dual purpose in the complete system. First, they provided a means for the material to transfer to the HC-75 semi-dense conveyor after it has exited the railcar. Second, because each Air Shoot can maintain material in a fluidized state, sodium carbonate could move quickly with very low pressure.

The covered Air Shoot conveyors featured consistent air flow to transfer product in a fluidized state at a shallow, horizontal angle with relatively low maintenance costs. Because there are no moving parts associated with Air Shoot conveyors, simple operation was ensured. Minimal overall room was necessary, keeping the unloading pit depth to a minimum. At

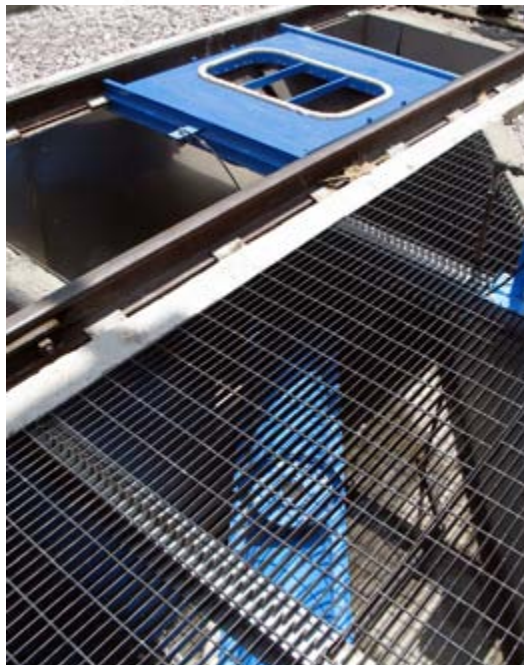

Figure 4. Three 12-inch dust-free Cyclonaire Air Shoot™ fluidizing conveyors, which transfer material at a horizontal plane using low-pressure air, were installed from the outlet of each CycloLift™ connector. Because minimal overall room is necessary, the unloading pit depth was kept to a minimum.

the P&G plant, an existing pit was refigured to handle installation of the Air Shoot conveyors. Much of the service and maintenance access to the equipment was kept above ground; and no electrical components were installed within the pit. Aeration air for the Air Shoot was supplied through standard source aeration valving on the HC-75, eliminating the need for auxiliary blowers or expensive compressed air and added controls.

At the heart of the P&G system was the pneumatic conveyor model itself: a vacuum-loaded Cyclonaire HC-75 Semi-Dense phase conveyor (high capacity – 75 ft³ volume tank), with three material inlets. Each inlet on the HC-75 was connected to one of the CycloLift Connectors, via the Air Shoot conveyors that supplied material. The HC-75 Conveyor featured a high-level, radio signal sensor to ensure safe, automatic filling and included two, built-in Sight Glasses for added user assurance.

Cyclonaire HC-Series conveyors have a conveying capacity of more than 80 tons per hour depending on the application. At P&G, the HC-75 was designed to more than double the convey rate previously moving



just 11 tons of sodium carbonate to the storage silos or plant per hour. The new system easily exceeded the 25 tons per hour requirement. Because HC Series conveyors use only positive air pressure for both vacuum loading and pressurized conveying, there was no need for high-maintenance filtration at the rail side and no close-tolerance rotary valves that could result in lost air. Standard automated controls also allowed for minimal operator supervision.

One medium positive-displacement 350-hp blower package — using 1,000 cubic ft. of 15-psig convey air per minute — was installed to supply pressure convey air to venturi-vacuum load, ensure Air Shoot aeration, and fluidize and convey sodium carbonate into the 70-foot-high silos. The high-efficiency blower package moved materials at the right combination of line velocity and material-to-air ratio to minimize abrasion and maximize efficiency. The P&G Vallejo plant realized a \$15,000-annual cost savings by not having to replace the previous blowers biannually. The Cyclonaire Blower Package was custom engineered to suit the extreme elevation and climate characteristics of the area. Built-in sensors monitor the changing temperature and air pressure to account for extreme climate shifts or mild fluctuations.

To direct material obstruction free to two different silos, the company purchased a Cyclonaire pinch-style diverter valve. The valve was configured to a specific angle of divergence to match pipe routing considerations and maximize flow. Valves came standard with double-wall construction for extended service life. Ten-inch convey lines, including several convey line elbows, provided transfer of the material more than 100 meters to the two storage silos. No additional air boosters were necessary.

SUMMARY

In all, the new automatic system has performed more than two times faster than the previous system, while reducing operator time each day and eliminating the need for one operator position entirely — a worker who previously oversaw railcar unloading. What used to take one hour in freight car maneuver time, takes only 10 minutes using Cyclonaire CycloLifts. Cost-savings and power and electrical consumption were also realized because the system is fully integrated. The company said that



Figure 5. A 10-inch-wide pinch diverter valve directs material obstruction-free to two silos. The valve was configured to a specific angle of divergence to maximize flow, and came standard with double-wall construction for extended service life.

an estimated \$281,000 annually would be saved in the reduction of energy consumption and decline in maintenance costs and replacement equipment. Additionally, spillage that once contaminated the environment was noticeably reduced.

“Excellent equipment, but even better (was) the personal service and follow-up,” the P&G Vallejo plant manager wrote in a prepared description about the project. “What Cyclonaire quoted was achieved 100 percent.” He said that throughout the project — from consultation and design to implementation and training — Cyclonaire engineers effectively oversaw every aspect of the project. Vallejo plant employees were enthusiastic about using the new equipment and liked its ease of use. The plant manager also said he would recommend Cyclonaire and its equipment to other Procter & Gamble operations.

The selection of Cyclonaire equipment used at the P&G plant is sold separately to meet the needs of individual customers, but can be integrated to form a comprehensive rail loading-and-unloading conveying system — as was the purpose at the P&G Vallejo plant.

To see photographs, dimensional drawings, and specifications for any Cyclonaire product, visit the Cyclonaire website at www.cyclonaire.com. To obtain more information and free literature, contact Cyclonaire Corporation, PO Box 366, York, NE 68467-0366; call 1-888-593-6247 or 1-402-362-2000; or send e-mail to sales@cyclonaire.com.

From Concept to Completion



Cyclonaire gives you experienced system design – using unequalled equipment backed by exceptional personal service. We engineer and manufacture material handling systems specializing in pneumatic conveying. Cyclonaire provides expert start-up assistance plus ongoing maintenance support.



©2009K Cyclonaire Corporation CYCA-523

888-593-6241
 Outside U.S. and Canada 402-362-2000
www.cyclonaire.com

cyclonaire®
 PNEUMATIC CONVEYING SYSTEMS

Multiple patents issued and pending

Conveying Solutions — contact us for information on these and other Cyclonaire components.



Bulk Bag Unloader



VibraPad™ Aerator



Rotary Airlock Feeder



CycloLift™



Line Injector



Divertor Valve



CB Series Blender

Explosion Pressure Relief: Vent or Door?

By Jef Snoeys, Manager of the Explosion Protection Technology Group for Fike.

DAMAGE FROM explosions occur primarily from the excessive pressures generated and the inability of process systems to contain such pressures. The most commonly used method of protection is explosion venting. In its simplest form, an explosion vent is an aperture in the top or side of a vessel that provides a means of pressure relief during an explosion in order to achieve a reduced explosion pressure (Pred).

Industry standards such as EN14491 and NFPA 68 describe a comprehensive method to calculate vent areas and design venting systems. The venting design variables are dependent upon:

- normal operating pressures.
- protected vessel volume and shape.
- maximum pressure generated by the explosion.
- rate of pressure generation by the explosion.

The standards also recognize the efficiency of the venting devices themselves. Industrial explosion venting devices are categorized as explosion vents or explosion doors. Explosion vents are sometimes describes as “devices which disintegrate at a defined activation pressure and which will keep the vent area permanently open;” whereas explosion doors will “open the vent area at a defined activation pressure and generally re-close after discharge.” In other words, explosion vents are one-time use devices, whereas explosion doors are designed for re-use after an explosion. In the following sections we will take a closer look at the specific differences between explosion vents and explosion doors.

VENT EFFICIENCY AND VENT AREA

Explosion vents are manufactured of thin stainless steel sheets, (1 to 2 mm) making them lightweight and able to provide a full opening almost immediately.

Conversely, explosion doors are much heavier and in some cases, the pressure increase before full opening is reached may exceed the equipment strength. Explosion doors are generally effective in protecting equipment with a minimum design strength of 2 bar, whereas explosion vents are used to protect low strength enclosures which are only 0.3 bar strong.

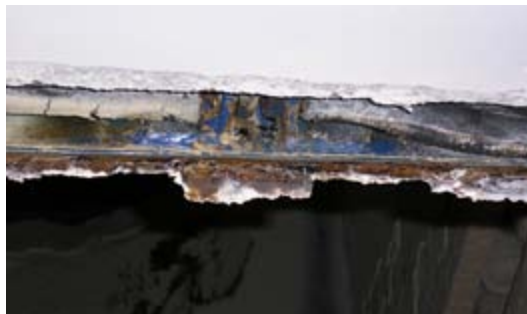



EXPLOSION PROPAGATION

The use of explosion pressure relief devices will not eliminate the propagation of flames through ducts and pipes connected to the protected equipment. When allowed to propagate, explosions tend to become more violent resulting in cascading damage which can potentially destroy entire facilities. Regardless of the protection measures considered, explosions must be prevented from propagating to other locations within the plant. Explosion Isolation systems prevent the propagation of flame through the use of fast-acting valves and/or chemical barriers — effectively eliminating secondary explosions.

The illustration shows the reduced venting efficiency of explosion doors when compared to explosion vents for a particular set of test conditions. To achieve the same reduced pressure, the area of the explosion door would have to be increased by applying the experimentally derived efficiency factor EF.

Ake Harmanny of Stuvex Benelux reported (VDI report n°975, 1992) on numerous explosion tests conducted on different vessels, provided with explosion doors of different masses. As expected, the mass adversely affects the efficiency of the explosion door. The investigations also showed that the efficiency of such doors is highly dependent upon the protected volume and the explosion severity (Kst): the bigger the protected volume, the more efficient the explosion door will be; however, higher Kst's lead to lower vent door efficiencies.

CONSTRUCTION

Inherent to being a consumable part, an explosion vent can be easily produced from materials compatible to the protected process. For the same reason, they can be constructed in such way that a tight closure can be guaranteed.

With explosion doors, both the door and the protected vessel have to be designed to withstand the impact forces generated by the opening of the door, due to the higher pressures generated. Door hinges or retaining cables must be strong enough to withstand the generated forces. In addition, all parts of the door, including the process wetted parts, must be of high quality in order to offer a consistent performance level during the lifetime of the product. Corrosion of the hinges and seals are reported to be problem areas for explosion doors, possibly increasing the opening pressure of the door and consequently decreasing the venting efficiency.





INSTALLATION AND MAINTENANCE

Explosion vents are available with standard flange ratings and bolt patterns. This flexibility allows the engineer to install the explosion vent in the optimum position with reference to both the process (vessel interconnections/equipment) and natural forces such as wind or snow loads.

Corrosion due to ice, snow load or an unprofessionally applied coating on the moveable parts of an explosion door, will result in an increasing activation pressure. The operation of the explosion door and the static activation overpressure, have to be checked in predetermined intervals. This means the explosion door should be easily accessible. However, during normal operation, access to the vicinity of the explosion door must be restricted, resulting in conflicting requirements.

Because they are passive explosion protection devices, explosion vents do not require special maintenance when properly designed and installed. This allows explosion vents to be installed at locations where access is restricted (high elevations, etc.), and therefore safer.

VACUUM

Typically, an explosion door will reclose after an explosion. Cooling of the hot combustion gases may create a vacuum in the protected vessel. To prevent vessel distortion, vacuum breakers must be provided in addition to the explosion door.

Explosion vents remain open after activation, preventing build-up of vacuum pressure.

CONCLUSIONS

Explosion pressure relief can best be achieved through the use of devices which cannot be tampered with and which offer the highest venting efficiency. Due to the inherent weight and constructional restraints, explosion doors should be selected with caution and for specific higher pressure applications. Critical parameters such as pressure integrity and venting efficiency, must be taken into account when considering the use of explosion doors. Additional vacuum breakers may also be necessary to prevent vessel collapse after an explosion event.

Explosion venting is the most common and

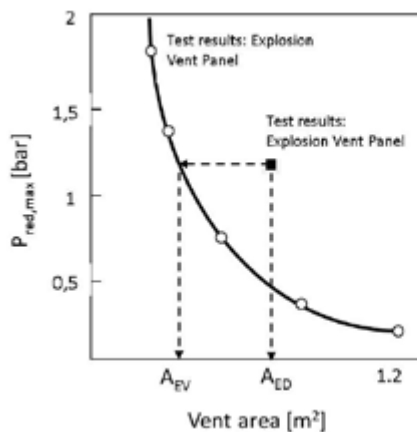

Venting Efficiency

$$E_F = \frac{A_{EV} \times 100}{A_{ED}} \text{ in \%}$$

effective form of explosion protection. Superior process compatibility, combined with ease of installation and maintenance, has made explosion vents the preferred choice since 1945.

In some cases it may be desirable to recover the vent relief area immediately following the explosion, for instance to allow for the more efficient application of fire fighting agents. For this purpose, there are special re-closable explosion vents, which return to their original position at the end of the venting process. These types of vents effectively provide the advantages of light weight explosion venting, with the reclosing function of explosion doors.

Think an explosion will never happen in your facility?

Dust and gas explosions are deadly and commercially devastating. Many facilities are at risk, but just don't know it. Fike is a global leader in the development and manufacture of reliable explosion protection solutions. And we offer a wide range of explosibility tests designed to assist you in identifying costly explosion hazards.

Rely on Fike's Explosion Protection Expertise

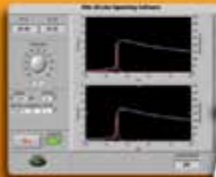

With over 40 years experience in developing innovative explosion protection technologies, Fike has the expertise to help you improve the safety of your facility and comply with changing regulations... all without spending a fortune.

Fike[®]

WWW.FIKE.COM

1-866-758-6004