

# Filtering Samples to On-Line Analyzers

**Guidelines for Proper Filtration  
and Delivery of Samples to  
On-Line Process Analyzers**

aerospace  
climate control  
electromechanical  
**filtration**  
fluid & gas handling  
hydraulics  
pneumatics  
process control  
sealing & shielding

# Filtering samples to on-line analyzers

## Use these guidelines to ensure proper filtration and delivery of samples to on-line process analyzers

Ken Perrotta, Division Engineering Manager  
Allan Fish, Product Manager  
Parker Hannifin Corporation  
Filtration and Separation Division  
Haverhill, Massachusetts

Increasingly precise process control strategies, often linked to computer control, have accelerated the use of sophisticated on-line chemical composition analyzers in plant applications. Instruments such as gas and liquid chromatographs, ion chromatographs, laser optic instruments, atomic absorption instruments and specific ion analyzers, which were rarities in laboratories ten years ago, are now found routinely in plant settings. While continuing miniaturization and "ruggedization" of the electronics are making the instrumentation circuitry more tolerant of the plant environment, a problem that will not diminish is the level of contamination in plant samples compared to laboratory samples.

Factors in plant operation that magnify the difficulty of delivering acceptable samples to on-line process analyzers are:

- The sample stream must be processed and fed to the analyzer continuously, rather than the batchwise method permissible in the laboratory.
- Test frequency in the plant is far greater than in the laboratory. Where a laboratory analyzer might perform 100 tests a month, an on-line plant analyzer could do 100 tests a day. In the high frequency plant usage, trace contaminants that would not be a problem in the laboratory can rapidly build up and cause instrument failure.

**Filter requirements.** It is not surprising that contaminants in the plant samples are reported to be the most frequent cause of problems with on-line analyzers. While the

requirements for an effective filter in the sampling line is generally recognized, it is also important to recognize that it is usually necessary to use a filter specifically designed for sampling applications, rather than trying to make do with a general purpose or homemade filter.

The characteristics that a sample filter should have, in addition to filtering out contaminants, are:

- The filter must not change the composition of the sample, other than to remove unwanted impurities. Therefore, the choice of filter media generally is limited to a few chemically inert materials: glass, stainless steel and PTFE.
- Since the sample filter often is in a remote or inconvenient location, it must be capable of operating for a reasonable period between scheduled maintenance checks. Even more important, it should not be susceptible to unscheduled problems, such as filter element plugging or rupturing, between regular maintenance checks.
- Sample filter maintenance in the field usually is performed under adverse conditions by personnel who are not trained chemists; therefore, the filter should be designed for easy and uncomplicated maintenance. Filter elements should be rugged and not susceptible to handling damage; the unassembled housing should have a minimum number of loose parts, and the housing should be designed so that it is virtually impossible to install a filter element incorrectly.
- A filter should introduce minimum lag time into the system. Lag time can be dealt with in the sample system design (slip-stream sampling, for example), but sizable dead volume in the filter housing should be avoided. Since large reservoir volume is

desirable in many filter applications - such as compressed air or water filters - filters not specifically designed for sampling usually are not suited for analyzers.

Requirements for sample filters range so widely that specifying a filter is best done on a case-by-case basis. There is, however, one generalization that applies to all sample filter requirements: the filter must be able to separate efficiently a noncontinuous phase contaminant from the continuous sample stream phase. Specifically, the filter must be able to make the following separations, in addition to removing solid particles:

- Gas samples - remove liquid droplets
- Liquid samples - remove immiscible liquid droplets and gas bubbles.

Most filter media will do an adequate job of removing solid particles from liquids or gases, but the only practical commercial media that will separate liquids from gases, gas bubbles from liquids, and two immiscible liquids is resin-bonded glass microfiber media. All recommendations in this paper are based on resin-bonded glass fiber media.

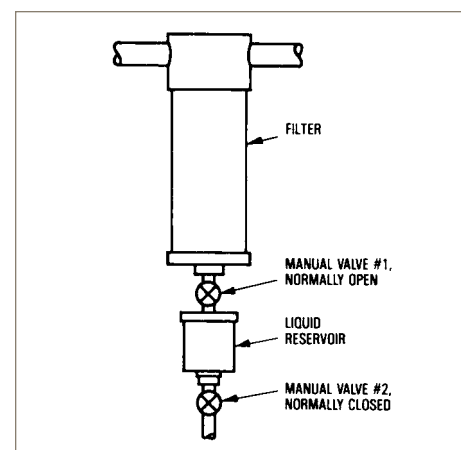

Figure 1: External reservoir for high pressure applications

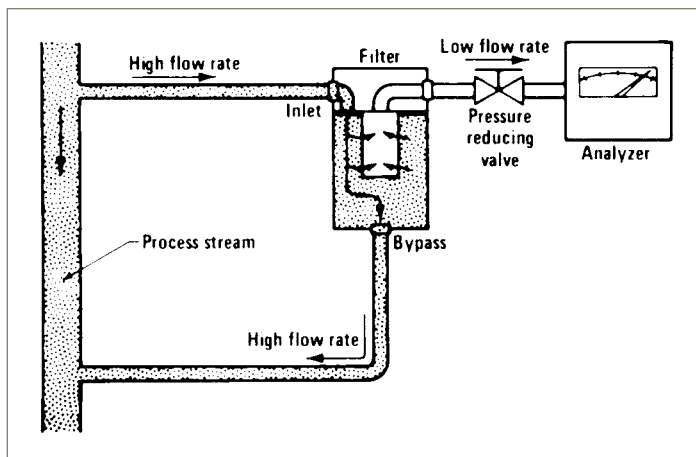

Figure 2: Slipstream or bypass filtration

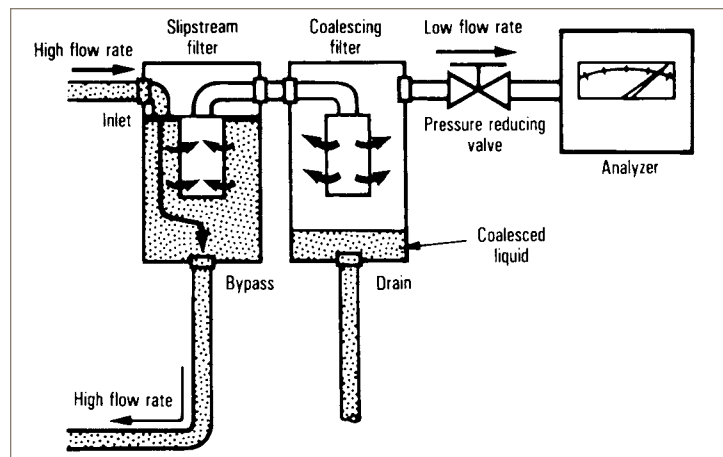

Figure 3: Slipstream plus coalescing filtration

**Separating liquids from gases.** Glass microfiber filter tubes efficiently separate suspended liquids from gases. The filter fibers capture the fine liquid droplets suspended in the gas and cause the droplets to run together to form large drops within the depth of the filter tube. The large drops are then forced by the gas flow to the downstream surface of the filter tube, from which the liquid drains by gravity. This process is called "coalescing". Since the coalesced liquid drains from the tubes at the same rate that liquid droplets enter the tubes, the tubes have an unlimited life when coalescing liquids from relatively clean gases, and the filters operate at their initial retention efficiency even when wet with liquid. The flow direction is inside-to-outside to permit the liquid to drip from the outside of the filter to the housing drain.

The filter tube grade should be selected for maximum liquid drainage rate, rather than maximum filtration efficiency rating. Since liquid drainage rate decreases with increasing filtration efficiency rating, this is a clear case where overspecifying filter efficiency will lead to unsatisfactory results.

If liquid is carried into the filter in slugs rather than dispersed as droplets in the gas, a filter that is properly sized for steady-state conditions can be flooded and permit liquid carryover. If slugging of liquid is expected, a filter with a relatively large bowl should be selected to provide adequate liquid holding capacity, and positive provisions should be made to drain the liquid automatically from the bowl of the housing as fast as it accumulates. An automatic float drain can be used if the pressure is in the 10 to 400 psig range. Above 400 psig, the upper limit for commercially-available float drains, the possibilities are: a constant bleed drain, a valve with an automatic timed actuator, or an external reservoir with manual valves (see Figure 1). The external reservoir can be constructed of pipe or tubing with suf-

ficient volume to hold all the liquid that is expected to be collected during any period of unattended operation. To drain liquid while the filter is operating at pressure or vacuum conditions, valve #1 is closed and valve #2 is opened.

If the filter is under vacuum, the external reservoir is a practical method of collecting coalesced liquid for manual draining periodically. Alternatively, if any external vacuum source is available, such as an aspirator, the liquid may be drained continuously from the housing drain port.

**Separating two liquid phases.** In principle, glass microfiber filter tubes separate suspended droplets of a liquid which is immiscible in another liquid by the same process as they separate droplets of liquid from a gas. The liquid droplets suspended in the continuous liquid phase are trapped on the fibers and run together to form large drops, which are then forced through the filter to the downstream surface. The large drops separate from the continuous liquid phase by gravity difference, settling if heavier than the continuous phase and rising if lighter. The coalescing action of glass microfiber filters is effective with aqueous droplets suspended in oil or other hydrocarbons, and also with oil in water suspensions.

In practice, however, liquid-liquid separations are much more difficult than liquid-gas separations. The specific gravity difference between two liquids is always less than between a liquid and a gas, and therefore, a longer phase separation time is needed. Either the filter housing must be oversized or the flow rate greatly reduced to avoid carryover of the coalesced phase. As a rule of thumb, flow rate for liquid-liquid separation should be no more than one-fifth the flow rate for solid-liquid separation. Even at low flow rates, if the specific gravity difference between the two liquids is less than 0.1 units (for example, if an oil suspended in water has a specific

gravity between the two liquids is less than 0.1 units (for example, if an oil suspended in water has a specific gravity between 0.9 and 1.1), the separation time for the coalesced phase may be impractically long. In that case, if there is only a small quantity of suspended liquid, the filter tube can be used until saturated with the suspended liquid and then changed.

Another practical problem with liquid-liquid separations is that small quantities of impurities can act as surface-active agents and interfere with the coalescing action. For that reason it is not possible to predict accurately the performance of a liquid-liquid coalescing filter, and each system must be tested on site. The general guidelines for the system to start testing are to use 25 micron filter tubes and flow inside-out at very low flow rates. If the suspended liquid is lighter than the continuous phase the housing should be oriented so that the drain port is up.

**Removing gas bubbles from liquids.** Glass microfiber filter tubes readily remove suspended gas bubbles from liquid, eliminating the need for de aeration tanks, baffles or other separation devices. Flow direction through the filter is outside-to-inside, and the separated gas bubbles rise to the top of the housing and are vented through the drain port. If slipstream sampling is used (see below), the separated bubbles are swept out of the housing with the bypassed liquid. Filter tubes rated at 25 micron are a good choice for gas bubble separation.

**Slipstream or bypass sampling.** Instrument sample use rates are invariably quite low, yet it is essential to minimize lag time in the sample system. Since analyzers often are located some distance from the sampling point, samples usually are transported to the analyzer at a relatively high flow rate to minimize lag time. The sample is divided at the analyzer, with the analyzer using the portion it requires (usually a very small fraction of the total sample), and the

balance recycled to the process or vented.

If the sample filter is located in the low-flow line to the analyzer, it will have good life between filter element changes because the solids loading rate is very low; however, the filter must be carefully selected to avoid introducing unacceptable lag time. If the filter is located in the high-flow portion of the sample system, its effect on sample lag time can be relatively low, but the life between filter changes may be inconveniently short because the element is filtering a much greater volume of material than the analyzer is using.

Ideally, a filter should be located at the point where the low-flow stream is withdrawn to the analyzer (see Figure 2). This arrangement permits the main volume of the filter to be swept continuously by the high flow rate system, thus minimizing lag time. At the same time, only the low-flow stream to the analyzer is filtered, thus maximizing filter life.

A slipstream filter requires inlet and outlet ports at opposite ends of the filter element to allow the high flow rate of the by-passed material to sweep the surface of the filter element and the filter reservoir, and a third port connected to the low flow rate line to the analyzer, which allows filtered samples to be withdrawn from the filter reservoir.

If bubble removal from a liquid is a requirement; this function may be combined with slipstream filtration, since the recommended flow direction for bubble removal is outside-to-inside, and the separated bubbles will be swept out of the housing by the bypass stream. In this case the liquid feed should enter at the bottom of the housing and the bypass liquid exit at the top of the housing.

A special problem arises in slipstream

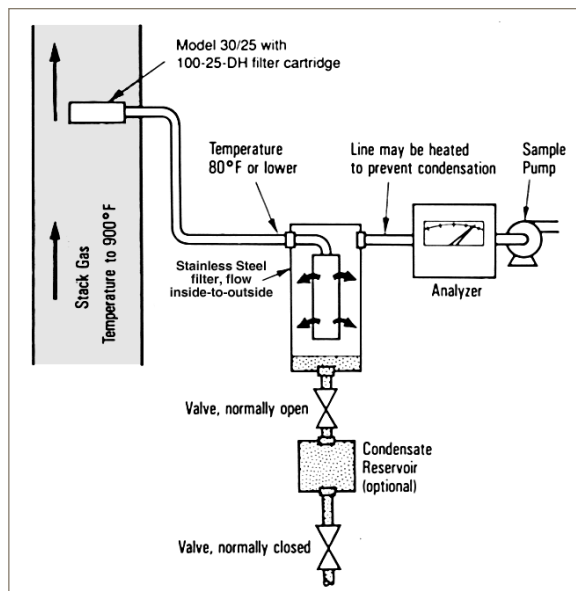

Figure 4: Stack gas sampling

sampling if the filter is to coalesce and continuously drain suspended liquid from a gas stream or to coalesce liquid droplets from a liquid stream. As noted previously, the coalesced liquid is removed in the form of large drops from the downstream side of the filter. Therefore, the coalescing filter requires two outlet ports, one for the dry gas and one for the liquid drain. To combine coalescing and slipstream filtration, a filter housing would need four ports - two for inlet and bypass and two for filtered gas and coalesced liquid - which is not a practical design. Therefore, slipstreaming plus coalescing requires two stages of filtration (see Figure 3). The second (coalescing) stage must be located in the sample line to the analyzer, and should be as small as possible to minimize lag time. If the quantity of suspended liquid is not large, a miniature in-line disposable filter unit may be considered as a trap for the suspended liquid, to be replaced when saturated.

**Stack gas sampling.** When sampling hot, wet gas, such as stack gas, a filter capable of withstanding the gas temperature can be installed in the stack at the beginning of the sample line to prevent solids from entering the gas sample line. After the sample is cooled, a coalescing filter is used to remove suspended liquids before the sample goes to the analyzer (see Figure 4). Flow direction is inside-to-outside. Filter housings with Pyrex glass bowls are often used in this application to permit a visual check of the liquid level in the filter housing. Since there is often a considerable amount of liquid present at this point, steps must be taken to drain the housing to ensure that liquid does not build up and carry downstream to the analyzer.

The liquid coalescing filter should be

located as close to the analyzer as possible to minimize the chance of condensation between the filter and the analyzer. Additional precautions that can be taken to avoid downstream condensation include cooling the sample below ambient temperature upstream of the coalescing filter, and heating the line gradually between the filter and the analyzer.

**Sampling liquid effluent streams.** Liquid effluent analyzers usually deal with aqueous streams having a high solids content. In addition, the analyzers are often located in remote areas of the plant and are infrequently serviced. Therefore, the sample filter system must have long life between filter tube changes even in a high solids situation. The general recommendation for this requirement is a two-stage filter system, a 75 micron prefilter followed by a 25 micron final filter. The filters should be oversized as much as possible without causing excessive lag time. Plastic filter housings are usually a good choice.

**Sampling high pressure steam or condensate.** Measurements are often required in high pressure boiler systems of steam and condensate conductivity, specific ion concentrations and feedwater additive concentrations. In a continuous sampling system, the high pressure steam or condensate is cooled to below 100°F and then reduced to near atmospheric pressure for metering to the analyzers. Filtration is required upstream of the pressure reducing valves, to prevent pitting of the valve seats by suspended particles and to eliminate variations in flow rate to the analyzers.

A stainless steel filter housing with the appropriate pressure rating and 25 micron filter tube is recommended. Since the analyzer system is often located some distance from the sampling point, slipstream filtration is usually required. Figure 5 shows a sampling system in operation at a steam generating facility.

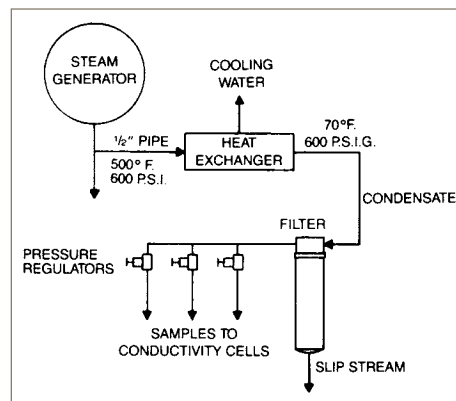
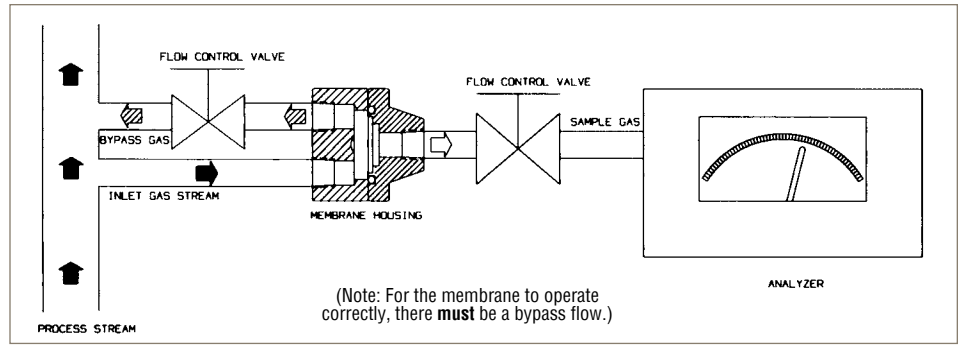

Figure 5: High pressure steam sampling

**Hydrophobic membrane sampling.** Many online instruments are susceptible to corrosion and skewed analysis from any water and moisture contamination. Gas chromatographs, mass spectrometers, oxygen analyzers and other sensitive on-line instruments require complete removal of all moisture. Instrument sensitivity levels range from PPM to PPB and “percent level” component concentrations.

As a result, it is good practice to install a hydrophobic membrane filter in line to the instrument to protect and safeguard it from any moisture contamination. A stainless steel filter housing with a hydrophobic membrane allows the sample gas to flow on the upstream side of the membrane and exit through the outlet port on the downstream side (see Figure 6). Entrained moisture will not flow through the membrane and will exit out the by-pass port on the upstream side of the membrane completely protecting the instrument from moisture.

If the sample gas contains excessive amounts of moisture and particulates it is recommended to use a stainless steel filter housing that incorporates a coalescing prefilter and the hydrophobic membrane (see Figure 7). The coalescing prefilter will protect the membrane from premature blinding and extend its useful life.



**Figure 6**

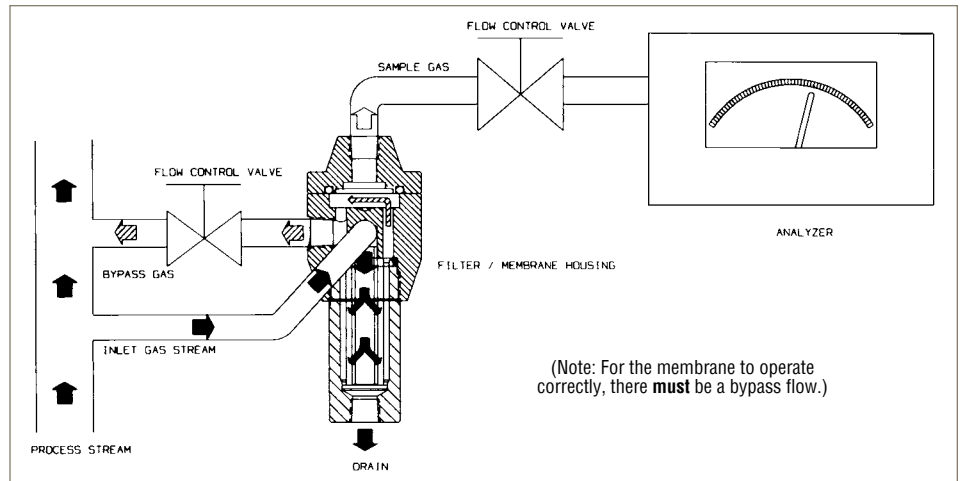

**Figure 7**

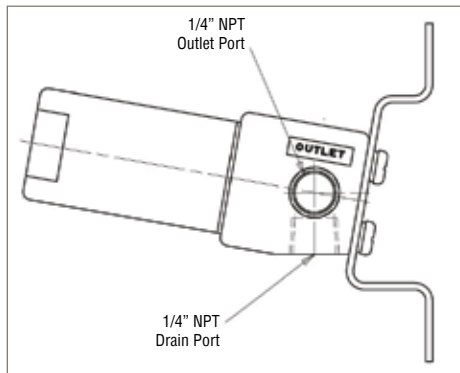

**Figure 8: Horizontal mounting**

**Minimal panel space, permanent line mount sampling.** As more and more sample lines and instruments are added to instrument sheds, the need to utilize the space in the most efficient way has become critical. In addition, the need to maintain sample filters without having to “break” the sample line and expose it to ambient conditions has also become quite important to most facilities. By not having to “break” sample line the need to flush the lines prior to start up is eliminated.

For this application, it is recommended a stainless steel filter designed to be horizontally mounted at a 10 degree angle be installed to minimize the amount of foot print on the panel (see Figure 8). This design incorporates the inlet ,outlet and drain ports all in the head of the filter enabling filter element change outs without disrupting the sample line.