



A WHITE PAPER

Consider the Unique Requirements of Chemical Industries When Selecting ERP Software

*Support for off spec materials, formula management,
changeovers, parallel operations, lot trace and trace,
unlimited unit of measure conversions, is key*



Table of Contents

Overview	3
Compliance Overview.....	4
HAACP/REACH Compliance	5
Managing and Reducing Costs	6
Off-Spec Materials.....	6
Formula Management.....	7
Capacity Utilization and Optimization.....	8
Flexible Routings	8
Quality Control and Management.....	9
Managing Inventory	9
Managing/Improving Customer Service	10
Shelf Life	10
Batch Attributes	10
Lot Track and Trace.....	10
Material Safety Data Sheets (MSDS).....	11
Summary.....	12
About Fullscope	13



Overview

There are a host of enterprise resource planning (ERP) and supply chain management applications available to chemical manufacturers—the challenge is selecting the right one that offers a baseline product with industry-specific functionality. Many ERP applications available today are not industry-specific enough for chemical manufacturers and require major modifications, or, one must select from an industry template that may or may not fit specific needs. There is also the chance that the software provider may not exist in two to three years (e.g., it may be acquired and the product's future may become unknown), or the provider may not be financially secure, adding long-term risk.

When selecting an ERP application, it is important to match application features to corporate objectives. Process manufacturing companies, including chemical companies, have some of the same requirements as discrete manufacturing companies, such as Sarbanes-Oxley compliance, plus many unique ones. Among the specialized requirements for chemicals manufacturers are:

- green/hazard analysis and critical control point (HACCP)/ registration, evaluation, authorization and restriction of chemicals (REACH) compliance
- cost control unique to process
- capacity optimization
- quality management and control
- multi-dimensional inventory visibility across the enterprise and
- enhanced customer service/perfect order metrics.

This white paper will help chemical manufacturers who are considering a new ERP application make the right choice to mitigate risk, and manage and control these industry-specific areas.



Compliance Overview

In the U.S., companies are subject to a host of agency regulation and oversight. The Environmental Protection Agency (EPA) governs and monitors spills, emissions, releases and exposures to hazardous and toxic materials and substances. The Occupational Safety and Health Administration (OSHA) monitor workers health and safety in the workplace. The Department of Transportation (DOT) monitors storage, use and transport of these materials. Hazardous waste is under the control of the EPA and subject to state regulations. Food and drugs fall under the auspices of the Federal Drug Administration (FDA), which regulates ingredients that go into these products. Finally, any fungicide, pesticide, or rodenticide used or manufactured falls under the EPA as well. Canada's regulations closely follow U.S. equivalents. Most U.S. chemical law falls under the Toxic Substances Chemical Act (TSCA) of 1976 which places the burden of chemicals compliance on the companies that manufacture them.

"Adequate data should be developed with respect to the effect of chemical substances and mixtures on health and the environment, and the development of such data should be the responsibility of those who manufacture and those who process chemical substances or mixtures ..."

Source: Toxic Substances Chemical Act of 1976

Consequently U.S. chemical manufacturing companies are responsible for compliance to all the public agency's requirements for control and measurement of their products.

In Europe, the new Registration, Evaluation, Authorization and Restriction of Chemical substances (REACH) regulations now in effect add complexity for companies doing business in the European community. The key element of REACH for chemical manufacturers is that the compliance responsibility has been shifted from government agencies to industry manufacturers. Chemical manufacturers now have until 2018 to provide data on hazards and risks, and demonstrate safe usage of individual substances, substances in preparations and articles. In addition, REACH requires dossiers documenting potential hazards; amount produced and intended use for each chemical produced. Non-compliant substances will be pulled from European market.

U.S. companies shipping product into the European community must register their products under REACH, and European companies must register their products and understand intended use within their supply chains. These regulations imply software components such as quality management and document management supported by a material safety data sheets (MSDS) application are resident in a chemical company's ERP system.



Green Compliance

The trend today is all about the “carbon footprint,” but for chemical companies, compliance requirements extend beyond carbon. Many chemical companies are limited or regulated by the EPA for waste water (effluent) production as well as emissions. In some cases there are limits to the amount of physical product they can ship to the landfill. But, the question is: how to manage those limits?

Formula-based process ERP applications allow manufacturers to define processes to include waste, scrap and by-products. So when planning runs are executed, the resulting production plans will identify the amount of by-product or waste generated from each plan. The by-products or waste could be effluent that is sent to the water treatment facility or smokestack emissions. If these are set up as hard constraints, the manufacturer can measure or limit production to comply with standards in place. These non-balance resources can also include things like energy consumption, which would allow a company to schedule production at off-peak hours when energy costs are lowest, again reducing the carbon footprint and helping to bolster the green image.

HAACP/REACH Compliance*

Compliance with these agencies requires an ERP system to capture and track all sorts of quality data at the item/lot level. The information must often be captured from a vendor's ingredients and manufactured intermediates and finished goods. Here's a sample of the extent of data that must be captured in the ERP application's quality and MSDS (Material Safety Data Sheet) system:

- Physio-chemical characteristics such as boiling point (batch attributes)
- Product efficacy and stability (shelf life and best-before dates)
- Hazard characteristics such as flammable or corrosive (MSDS)
- Poison inhalation hazards (MSDS)
- Mammalian toxicity, e.g. toxic to rats (QC Data)
- Data needed to assess exposure (OSHA)
- CAS (Chemical Abstracts Service) Numbers and other identifiers (QC Data and MSDS)
- Personal protective equipment needed (MSDS)
- Data to support the formulation confidentiality (electronic signature, document management)
- Data from QC/QA system (batch attributes)
- Data to support FDA validation
- Database of required MSDS documents
- ERP data: production, customer, regulatory, supply chain, worker exposure.

An ERP system for a chemical company should support these basic compliance requirements listed above. In addition, most chemical companies will need a subscription service to track regulatory issues by country/state and import appropriate text into the ERP application for MSDS reports, labels and transport documentation.

In summary, compliance for global chemical companies is becoming more, not less, complex. Customers, government agencies and other stakeholders are requiring more regulation of chemicals, more testing to assess risks and more data to be managed collaboratively but securely.

**Source for this section: Lea Bream, Senior Council Compliance, Degussa*



Managing and Reducing Costs

Off-Spec Materials

One key area where a process-specific ERP application can help chemical manufacturing companies reduce costs is the area of rework and reblend. When any production run falls short of specific quality characteristics, the options are to scrap, rework, regrade or reblend. The optimal ERP system will support all four options.

Rework takes an existing batch (item lot combination) and rolls up the materials, labor and overhead costs into the primary batch cost sheet. The rework order should start with these costs and then add additional materials, labor and overhead as the batch is reworked to meet quality standards. A rework order differs from a standard order in terms of formulation routing, timing, processes and costs. So with minimal effort, a production line worker can take an off-spec batch and launch a rework order to normalize the quality, all with minimum effort.

Reblend is another option. Ideally, the formula should be consumed as an ingredient that can be defined as reblend or off-spec materials. Defining formulations as percentage-based allows manufacturers to specify 10% off-spec materials when possible. This formulation will issue a pick list to alert production to use as much off-spec materials as possible in any given formulation. Off-spec materials are one of the costliest elements of chemical manufacturing, and the ability to use them during production offers huge cost savings.

The third option for off-spec materials is to *regrade* the product, which, in most ERP applications, would suggest an item number change, a practice that implicates costing issues, lot track and trace, customer service and manufacturing efficiencies. The correct best practice for an ERP system is to retain the item number, and assign a dimension or grade to it. Regrading an item should retain the item number, but allow repricing or recosting of materials. Lot-level visibility should support inventory lookups performed at the item level but sorted by grade. Customer service can then select and sell the same item by grade and have the flexibility to offer higher or lower prices based on that dimension.



Formula Management

In the chemicals space, one of the key requirements is the inverse bill of materials (BOM), which refers to the ability to start with a raw material and, from it, produce many end items, co-products and by-products. All of the main components of ERP need to work with the inverse BOM, including planning, scheduling and costing. A formula-based ERP application offers tremendous flexibility in managing production and helping reduce costs in these areas:

- *Multiple recipes*: Mix-and-match formulas and routings to compensate for variability in quality of raw materials and different capacity work centers when optimizing batch sizes based on demand or available capacity.
- *Cost distribution*: The inverse BOM requires a costing model that distributes cost, as opposed to performing cost rollup, and to make sure the cost models are in place for this process.
- *Substitutions*: Support on-the-fly decisions to use less costly ingredients if and when available to achieve the same batch quality.
- *Scale formulas*: Based on the lowest common ingredient, only make the quantity that you can make, so that you use up key raw materials.
- *Cost effective*: Cost by-product, scrap, waste and yield for a true picture of the cost of intermediates or end items, and for better standards and lower production costs.
- *Unit of measure (UOM) conversions*: Track inventory stored in one unit of measure and consumed during production in a different unit of measure to help operations manage inventory in drums, pallets, rolls, totes, super sacks, etc., and define formulations in the most efficient unit of measure.
- *Recipes*: Set up specific formulations and processes by date range and size so planners can select appropriate formulations based on demand and assign the best batch/formula process.
- *Pack BOMs*: Support for specific packaging bills of materials and customer-specific pack bills of materials with customer-specific labels, packaging instructions and materials.

Capacity Utilization and Optimization

The right ERP solution for a chemical company should include or integrate with a finite capacity scheduling application and consider a work center's capacity when planning runs are executed. This will translate into a good starting point for the planner/scheduler for identifying short-term constraints due to materials and capacity. Most chemical manufacturers are more concerned with bottleneck resources than materials shortages, so the ERP system should identify both simultaneously. In some cases capacity will be defined as traditional run rates (i.e., packaging lines), and in some cases, capacity will be defined by volume-based constraints (tanks, silos, pipeline). Moving from execution (ERP) to optimization, one key for huge potential cost savings is in the changeover matrixes. By minimizing changeovers on the production floor, companies can increase availability of scarce resources and minimize changeover costs for increased throughput at lower costs.

Work can also be configured with infinite capacity, which some chemical companies find useful. In such circumstances, planners can consider the areas where capacity is exceeded and make decisions whether to outsource, schedule overtime work, or move the work to alternate work centers instead of allowing the system to simply delay the production of planned work that may exceed capacity.

Flexible Routings

The ERP solution should allow the setup of concurrently running, parallel operations and support concurrent stops and starts. While most ERP process routings are sequential in nature, chemical companies often launch parallel processes for intermediates, causing capacity planning to be more feasible and accurate. A company could start production of three or more intermediates to coincide with a blending operation, and all three would theoretically be ready at the start of the blend step.

Here's an example of a complex routing and how an ERP system should model it:

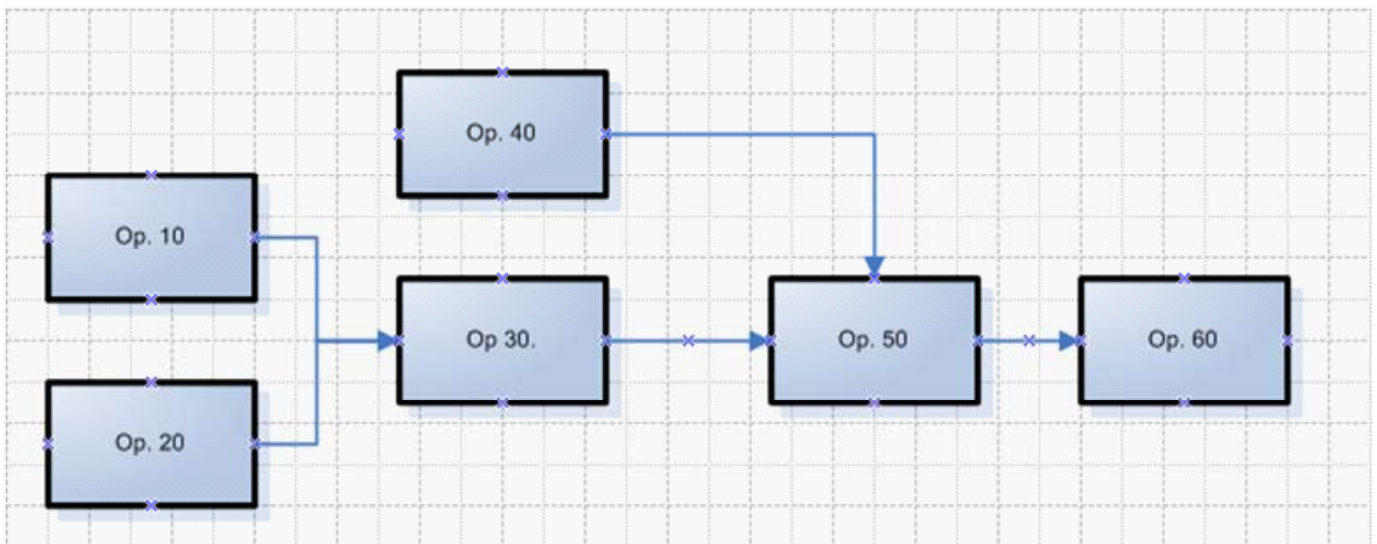

Operations 10 and 20 could be pre-mix stations, feeding a blending operation 30. The next sequence shows Operation 50 consuming the blend, as well as another intermediate from Operation 40, and finally producing an end item or bulk in operation 60. The keys are that operations 10 and 20 will be scheduled concurrently, as will operations 40 and 50, for more efficient planning.



Quality Control and Management

Because there is huge variability in raw materials, processes and finished goods in the chemical industry, an ERP application must be able to capture and manage quality specifications at every level of production and allow policies and procedures to be defined accordingly. The key areas of integration where quality management can be managed include:

- Purchase orders and purchase order receipts
- Standing inventory
- Batch work orders in production
- Integration with routing operations
- Finished goods reporting/sales orders
- Returned goods

The right ERP system will have a big responsibility in regard to quality control and management. On purchase order receipts, users should be able to monitor incoming raw materials for specific quality tests and set acceptability limits. These statistics, in addition to the three-way vendor match, are necessary to measure vendor performance. For standing inventory, quality orders should be automatically generated based on retest dates set up in the item master. Quality orders should be linkable to operations within the routing to prevent off-spec or contaminated materials from moving downstream. Finished goods should be testable and capable of having batch attributes. Finally, returns must be easy to monitor for quality and moveable into appropriate workflows. These workflows should drive item/lot dispositions, such as scrap, rework, reblend, regrade or simply return to stock "as is." Non-conformances should be generated and tracked to determine "where" and "why" quality mishaps are occurring and how to correct those conditions.

Managing Inventory

A multi-dimensional view of inventory is necessary so users can see where inventory is across the enterprise and search for it by these dimensions and attributes:

- *Lot number*: Individual instances of an item with specific attributes, quality, shelf life
- *Serial number*: A subset of a lot, allows the user to identify cases, totes, drums individually
- *Grade*: One of three user-defined dimensions allows designation of multiple cost or sales prices due to quality variation
- *Container*: Allows the user to see bulk product in its final packed-off configuration (bag, drum, palette, super sack, tote, railcar, etc.)
- *Disposition*: User-defined codes establish logical status for materials to determine whether they are usable for production or sales or are in a non-usable status
- *Batch attributes*: Quality characteristics of a lot and inventory searches performed by these individual test results
- *Shelf life*: Planning has visibility to shelf life and knows when materials are needed, and when they expire and plans accordingly.

The inventory management process is necessary to allow unlimited unit of measure conversions, which are generally issues in non-process-oriented ERP systems:

- *User defined*: Units of measure specific to an item (one case of 'Item A' might be different than one case of 'Item B'). Process Industries also comes with all the standard UOM conversions (for example, lbs to kilos).
- *Catch weight*: The ability to transact in actual weight/or volume. While a 2000 lb. tote might contain 2010 lbs or 1980 lbs, you can capture the actual weight (in this case 'lbs') against the Tote and value and bill at actual weight. The same holds true for volume-based material: one 55-gallon drum might contain only 27 gallons. It is important that the system be able to track the actual weight/volume along with the number of pieces of each of those variable storage units.



Managing/Improving Customer Service

Like many other process manufacturers, chemical manufacturers require a robust order management application. For this reason, an ERP system must have multiple features to enhance customer service, particularly in the areas of product shelf life and quality.

Shelf Life

In many industries, product potency or quality may diminish over time so product stock keeping units (SKUs) are assigned best-before dates as well as expiration dates. The right ERP solution will automatically assign both dates to every item/lot combination and allow flexible lot dating, so lot numbers and dates can be assigned by batch or time stamp. In semi-continuous production time stamps can become lots with specific quality attributes, allowing bracketed recall notices in case of quality issues. Customers can also request that lots shipped have specific days of shelf life remaining.

For chemical manufacturers, planning capabilities in the ERP system should allow users to view shelf life. For both raw materials and finished goods, an available-to-promise (ATP) inquiry is needed to look at the item's shelf life. The ATP action can then become a more accurate assessment of material available over time and prevent customer service from committing product to a customer that would expire prior to shipping.

Batch Attributes

Most chemical manufacturers produce to specific quality targets. Batch chemicals can have anywhere from one to two dozen quality attributes to track. In some cases their customers have the same or tighter specifications than the normal production runs. An ERP system must track these batch attributes.

- Quality tests or attributes are user defined, not limited, at the item level
- Customers can have specific attributes at the item level
- Customer service representatives can search inventory manually for specific lot/attributes
- Ship only those lots which map to a customer's requirements

When shipping product to customers with specific quality specifications, the ERP system must let customer service reach into inventory and reserve/ship only those lots that meet the requirements. This helps manufacturers map to Perfect Order KPIs and reduce returns based caused by shipping off-spec materials to customers.

Lot Track and Trace

Powerful and flexible lot track and tracing is necessary in an ERP system for a chemical company. The system should support quick and easy online searches from the minute a lot is generated or transacted. If a customer calls with an off-spec quality issue, customer service can easily track the finished good back to its original ingredients. If an ingredient is found to be defective, the user can immediately track all the intermediates and finished goods that consumed the suspect ingredient and notify stakeholders of possible quality issues.



Material Safety Data Sheets (MSDS)

A good ERP solution should address both key MSDS components: execution and subscription.

- *Execution*: store all appropriate text for the MSDS documentation, define which materials are regulated, track each customer that receives regulated materials, alert the user when new documents need to be sent with the shipment, define expirations dates for the documentation, and alert when new documentation needs to be granted.
- *Subscription*: MSDS subscription services track hazardous materials worldwide, determine and author health, safety, transport and cleanup documentation for each material. The subscription service should update the ERP system a minimum of once a month for all of the subscription items and countries.

Additionally, the ERP solution should track MSDS documents for both customers and vendors (for incoming raw materials) and generate the appropriate alerts. Reports and labels should be user definable during the implementation process.



Summary

Chemical manufacturers need to select an ERP system that is designed to support the industry-specific challenges of their process-oriented operations. With the right selection, they can meet and exceed government regulations, reduce supply chain costs, increase throughput and improve customer service and satisfaction.



About Fullscope, Inc.

Fullscope, Inc., is a Microsoft Gold Certified Partner that offers deep domain expertise for manufacturing companies with process, discrete and hybrid operations. The company developed Process Industries for Microsoft Dynamics AX; offers a Certified for Microsoft Dynamics (CfMD) solution for high tech industries, and is one of the largest Microsoft Dynamics AX resellers in North American. Sold only by resellers, Microsoft Dynamics AX is the Microsoft ERP solution for mid-to-large companies, and over 11,000 companies worldwide depend on it to run their businesses.

In its June 2009 *Magic Quadrant for Midmarket and Tier 2-Oriented ERP for Product-Centric Companies*, Gartner, Inc., "concludes that only one offering qualifies as a leader in the market at this time: Microsoft Dynamics AX. The product is robust and it delivers low TCO through integration with other Microsoft products."

For more information about Microsoft Dynamics AX and how it can help chemical companies improve their manufacturing operations, please contact Fullscope at info@fullscope.com or visit www.fullscope.com.



Fullscope, Inc.
2500 Northwinds Pkwy #600
Alpharetta, GA 30009

www.fullscope.com